



NEW
Size 210 / 240
with new Technologie

SP⁺ The New Generation

Low-Backlash Planetary Gearhead
SP⁺ and SP⁺ HIGH SPEED®



alpha

a WITTENSTEIN AG company

SP⁺ a step, a leap... You decide!

alpha's customers worldwide have come to expect that we set the pace for innovations. The time has come for the **SP** to step down for its successor: **SP⁺**. The + marks the new era of Low-Backlash Planetary Gearheads, in both cyclic and continuous duty operations.

What created this new benchmark product?

Its special characteristics, individually exciting, but together unique.

- Higher acceleration and output torques.
- Low standard backlash, optional < 1 arcmin.
- Improved output bearings for higher axial and radial loading capacities.
- 4 times quieter than the already quiet **SP**.
- Wide variety of available ratios, incl. binary.
- New proprietary shaft seals for IP65 protection.
- 100% quality testing prior to shipping.
- The only gearhead backed by a 20 year history of design and manufacturing innovations.



But that is not enough

SP⁺ features a positioning accuracy and impressive acceleration torques that previously were possible only with the alpha TP series. It has a markedly higher torsional stiffness and service life than competitive products. It can be flawlessly mounted to the motor in one single step. You'll be pleased not only as an engineer, but also as a business man, in demanding the highest in efficiency, productivity and process reliability.

Again alpha has converted its years of experience in gearhead design and manufacturing, with the **SP⁺** product taking performance and reliability to a new level of excellence.



SP+ - displays real character

Higher power density

Although its predecessor, the **SP**, already delivers exceptional performance, we have managed to increase the maximum acceleration torque of the **SP+** even further.

Any mounting position

Regardless of how your **SP+** is mounted, it always has the same amount of oil, eliminating the need to specify mounting position when ordering. Thus flexibility of machine mounting orientation is possible with one ordering code.

Motor mounting: Simply child's play

The motor can be accurately mounted in just one step, therefore mounting errors are impossible.

This patented alpha motor mount is also available with optional integrated linear length compensation.



Cutting edge innovations made by alpha

We have been developing, manufacturing and distributing low-backlash planetary gearheads, servo right-angled gearheads, complete drive units and planetary elevator machines with an integrated servo motor since 1984.

Profit from our comprehensive service package: from individual components to complete systems, supported by our competent engineering services, several hundred employees worldwide are committed to our cause with operations in the US, UK, France, Italy, Belgium and Japan. alpha's headquarters are on the "Romantic Road" in Igersheim / Germany.

alpha is a member of the **WITTENSTEIN AG** Group which has rightly established a name for itself with numerous innovations in industries such as aerospace and simulation, medical technology, elevator drives and Formula One racing.



Helical gearing delivers: Smooth, quiet running

SP+ whispers. The noise emission of the **SP+** is 6 dB(A) lower than that of our already quiet SP line, making the **SP+** four times quieter. What's more, vibration is dramatically reduced allowing smooth running for you.

Highest positioning accuracy

You know the classic precision of **SP** – now **SP+** provides a new world of precision. We have reduced the torsional backlash and can now offer you less than one arc minute of backlash on request, dramatically increasing positioning accuracy.

World-class lifespan

alpha's proprietary new seals for the **SP+** optimise both material and geometry, to provide true IP65 protection. In addition, the output bearing capacity has been improved to surpass anything in its class, giving the **SP+** a world-class lifespan.

Leaders of the pack

We are driven by a desire to enhance our customers' success with products and systems from alpha. We set benchmarks when it comes to precision, performance and durability. Our trailblazing technology gives our customers an edge in their respective market sectors. Place your trust in premium quality and total reliability from alpha. Choose world class engineering – the foundation for strong partnerships and added value that is passed on to your customers.

alpha benefits at a glance:

Record-breaking lifespan

Extremely long service life resulting from intelligent design, latest synthetic lubrication technology, exclusive sealing technology, and incredibly strong output bearings.

Motor mounting is almost foolproof

Simple and reliable mounting in a single step.

Top quality from alpha

In-house development and manufacture of all products combined with a pioneering spirit and an insatiable urge to improve.

alpha speedline®

speedline delivery if your production process can't wait. Dispatch of your alpha gearheads from our factory is guaranteed in just 24 or optionally 48 hours.

Our speedline delivery service has been operating successfully throughout Europe since 2004.

SP+ High Speed® stays cool

The trend is clear. Low-Backlash gearheads are being increasingly implemented in continuous duty operations at high speeds. This applies especially to the packaging, printing, textile, paper and semiconductor industries, but also in newly emerging markets of glass, food and hygiene products.

Gearheads that run around the clock literally must stay cool.

SP High Speed showed that was possible. **SP+ High Speed** will continue the success story.

Like its predecessor, the **SP+ High Speed** provides superior performance. It can be run continuously with a long service life. It gets no more than lukewarm even under highest stress, and it incurs no maintenance or service costs.

Achieving 99.9 percent reliability, while cooling the motor and increasing efficiency, has earned us the right to be called masters in our field.

SP+ accelerates with the new alpha speedline®

If your production process can't wait, why not order **SP+** with alpha's popular speedline service? Dispatch from our factory is guaranteed within a mere 24 or 48 hours.

Ask for more information about alpha speedline.
We look forward to speeding up delivery for you.





SP+® choosing correctly is so simple

SP+ for cyclic operation or SP+ High Speed for continuous operation

On each of the subsequent double-page spreads we introduce one **SP+ / SP+ High Speed** series. The left page contains the dimensions and drawings, the right page contains a table with technical data, ratios and the most important characteristic values. The data is listed separately for MF (**SP+**) and MC (**SP+ High Speed**) versions, one stage and two stages respectively.

As always, your personal alpha engineer is always available for a technical discussion.

Choose **MF (SP+)** for **cyclic operation S5**, where duty cycle is <60% and <20 minutes.

Choose **MC (SP+ High Speed)** for **continuous operation S1**, where duty cycle >60% or >20 minutes.

These guidelines cover most applications. Please contact alpha in special situations.

Ask for the SP+, the new quiet star of the Low-Backlash Planetary Gearhead universe.

SP+ Gearheads: Fast selection

Size	060			075		100		140	
				MF	MC	MF	MC	MF	MC
Maximum acceleration torque	T_{2B}	Nm	30-40	85-110	42-66	225-300	100-165	390-600	195-330
Nominal output torque	T_{2N}	Nm	17-26	47-75	26-42	120-180	65-105	200-360	120-210
Emergency stop torque	T_{2NOT}	Nm	80-100	200-250		500-625		1000-1250	
Maximum input speed	n_{1Max}	min ⁻¹	6000	6000	6000	4500	6000	4000	6000
Nominal input speed	n_{1N}	min ⁻¹	3300 - 5500	2900 - 4500	4500	2500-4200	3500-4500	2100-3900	3000-4500
Page	8 - 11			12 - 15		16 - 19		20 - 23	

Size	180		210		240			
	MF	MC	MF	MC	MF	MC		
Maximum acceleration torque	T_{2B}	Nm	880-1100	275-485	1600-2500	530-1000	2750-4500	870-1500
Nominal output torque	T_{2N}	Nm	530-750	170-305	1000-1500	340-630	1300-2500	560-1000
Emergency stop torque	T_{2NOT}	Nm	2200-2750		5000-5200		6800-8500	
Maximum input speed	n_{1Max}	min ⁻¹	3500-4000	4500-6000	2500-3500	3400-6000	2200-3500	3400-6000
Nominal input speed	n_{1N}	min ⁻¹	1500-3400	3000-4500	1200-2900	2500-4500	1000-2400	2000-4500
Page	24 - 27		28 - 29		30 - 31			

View A

Motor shaft diameter (mm)

View B

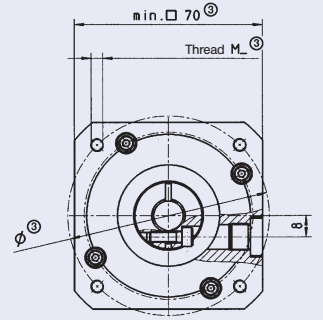
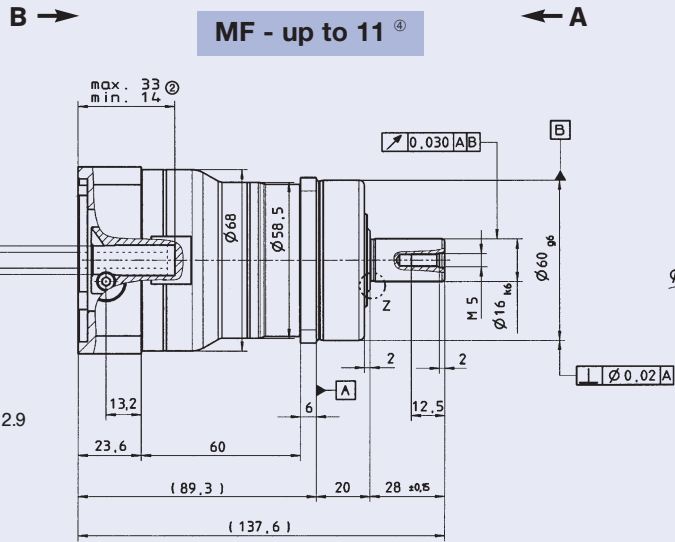
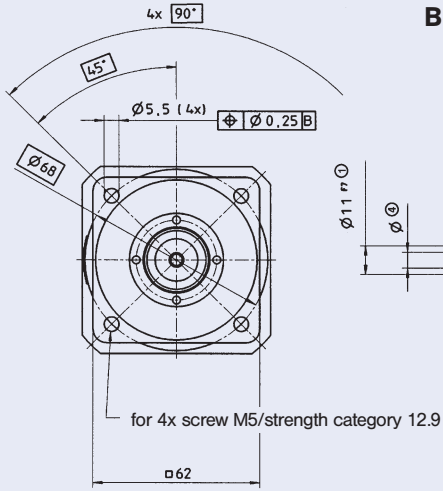

MF - up to 11^④

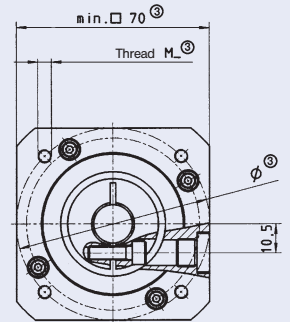
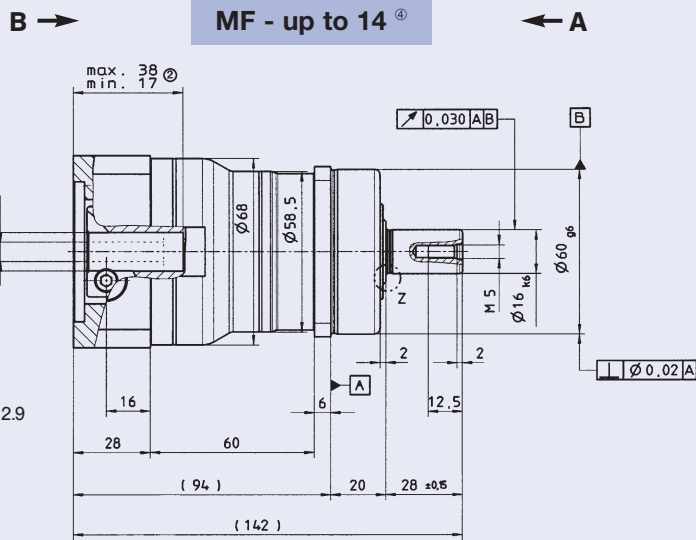
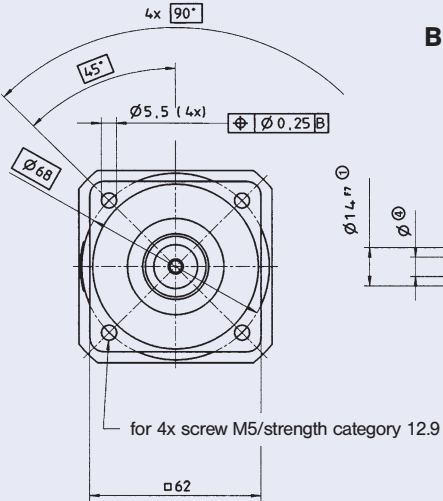

MF - up to 14^④

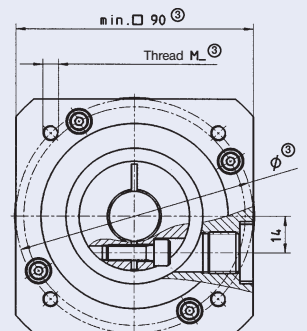
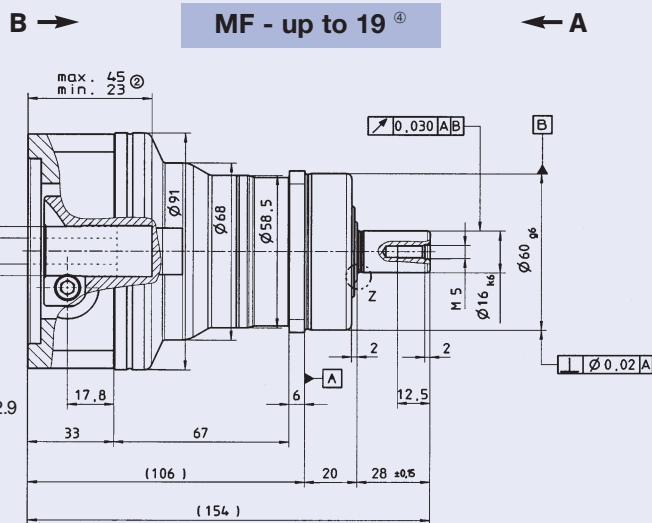
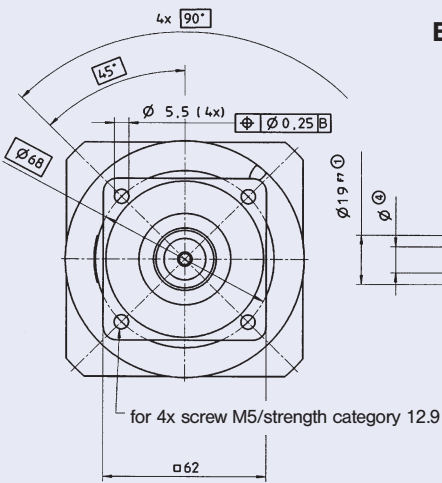

MF - up to 19^④

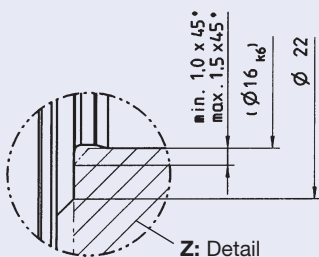

Dimensions without specified tolerances ±1 mm.

- ① Check motor shaft fit.
- ② Min./max. permissible motor shaft length. Longer motor shaft is possible. Please call alpha.
- ③ The dimensions depend on the motor.
- ④ Smaller motor shaft diameter is compensated by a bushing with at least 1 mm thickness (see page 34).

▲ Motor mounting according to operating manual.

Technical Specifications SP+ 060 1-stage

			1-stage					
Ratio *	i		3	4	5	7	10	
Maximum acceleration torque (Max. 1000 cycles per hour)	T_{2B}	Nm	30	40	40	40	32	
Nominal output torque	T_{2N}	Nm	17	26	26	26	17	
Emergency stop torque (Permissible 1000 times during the lifespan of the gearhead)	T_{2Not}	Nm	80	100	100	100	80	
Nominal input speed (At 20 °C ambient temperature) **	n_{1N}	min ⁻¹	3300	3300	3300	4000	4000	
Medial no-load running torque ($n_1=3000$ rpm) (At 20 °C gearhead temperature) ***	T_{012}	Nm	0.9	0.7	0.6	0.4	0.3	
Maximum input speed	n_{1Max}	min ⁻¹	6000	6000	6000	6000	6000	
Torsional backlash	j_t	arcmin	Standard ≤ 4 / Reduced ≤ 2					
Torsional rigidity	C_{t21}	Nm/arcmin	3.5					
Max. axial force ****	F_{2AMax}	N	2400					
Max. radial force ****	F_{2RMax}	N	2700					
Max. tilting moment	M_{2KMax}	Nm	152					
Efficiency at full load	η	%	97					
Service life (For calculation, see alpha Technical Basics catalog)	L_h	h	> 20 000					
Weight incl. adapter plate	m	kg	1.9					
Noise level ($n_1=3000$ rpm) *****	L_{PA}	dB(A)	≤ 64					
Max. permissible housing temperature		°C	+90					
Ambient temperature		°C	0 to +40					
Lubrication			Lubricated for lifetime					
Paint			Blue RAL 5002					
Direction of rotation			Motor and gearhead same direction					
Type of protection			IP 65					
Mass moment of inertia (Referring to the drive)	J_1	kgcm ²	11	0.21	0.15	0.12	0.10	0.091
			14	0.28	0.22	0.20	0.18	0.17
Clamping hub diameter (mm)			19	0.61	0.55	0.52	0.50	0.49

* Binary ratios (8) available as an option. Consult alpha.

** For higher ambient temperature, reduce nominal input speed n_{1N} .

*** Valid for clamping hub diameter 14 mm.

**** In reference to the center of the output shaft.

***** Measured at ratio $i = 5$ (without load).

Alternative output shaft versions

Keywayed output shaft in mm

E = Key to DIN 6885, page 1, form A

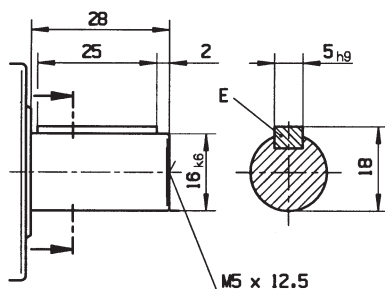

Involute gearing DIN 5480 in mm

X = W 16 x 0.8 x 30 x 18 x 6m, DIN 5480

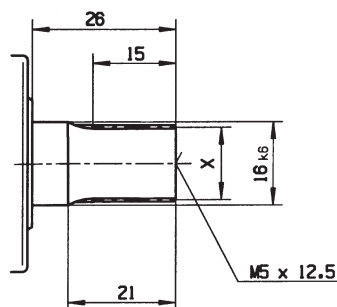

Conversion table

1 mm	= 0.039 in
1 Nm	= 8.85 in.lb
1 kgcm ²	= 8.85 x 10 ⁻⁴ in.lb.s ²
1 N	= 0.225 lb _f
1 kg	= 2.21 lb _m

View A

Motor shaft diameter (mm)

View B

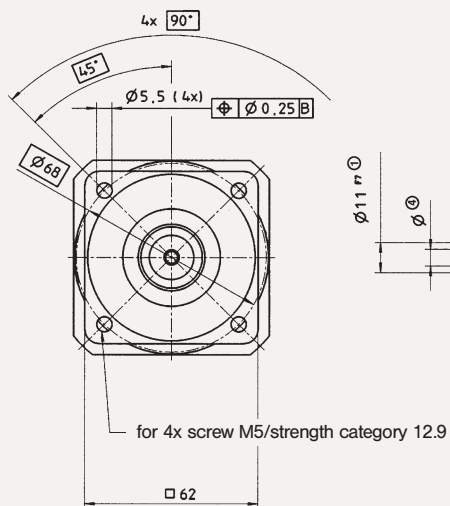

B →

MF - up to 11^④

← A

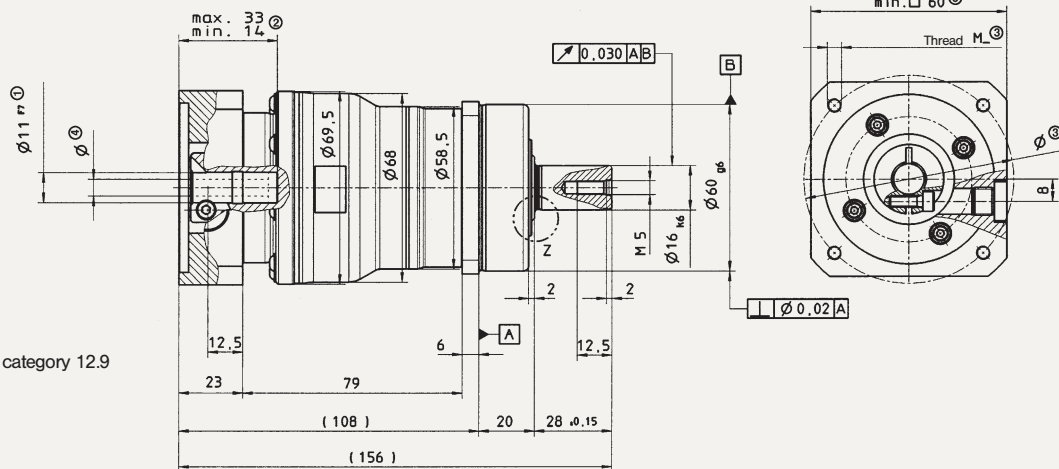

B →

MF - up to 14^④

← A

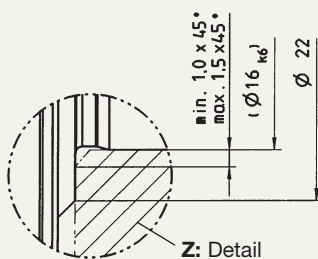
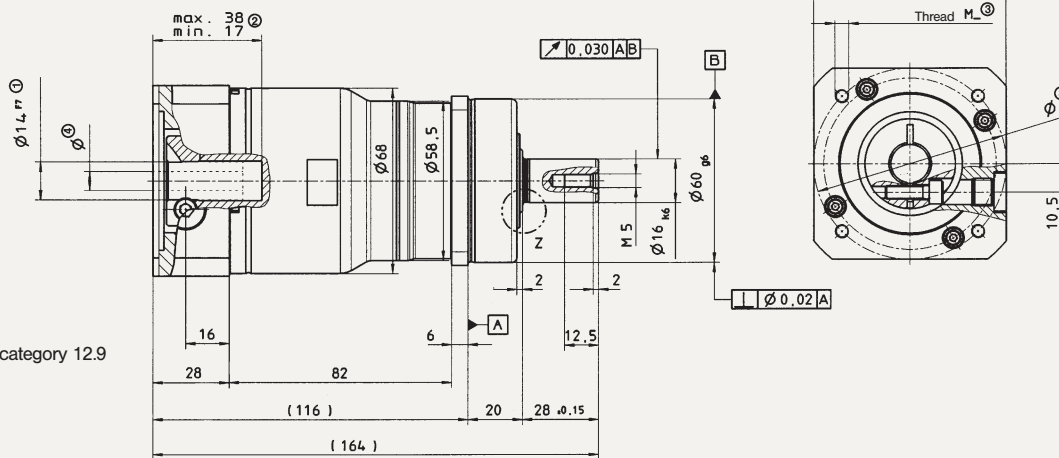
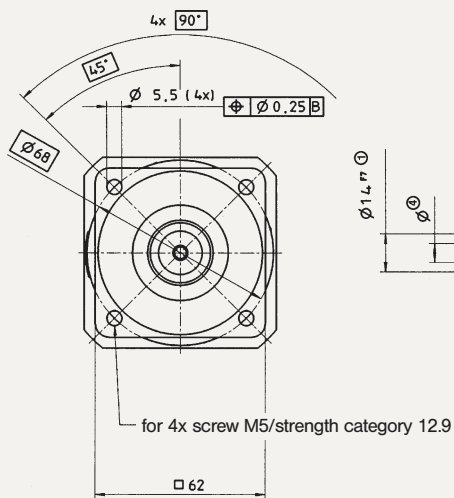

Dimensions without specified tolerances ±1 mm.

① Check motor shaft fit.

② Min./max. permissible motor shaft length. Longer motor shaft is possible. Please call alpha.

③ The dimensions depend on the motor.

④ Smaller motor shaft diameter is compensated by a bushing with at least 1 mm thickness (see page 34).

⚠ Motor mounting according to operating manual.

Technical Specifications **SP+ 060** 2-stage

			2-stage									
Ratio *	i		16	20	25	28	35	40	50	70	100	
Maximum acceleration torque (Max. 1000 cycles per hour)	T_{2B}	Nm	40	40	40	40	40	40	40	40	32	
Nominal output torque	T_{2N}	Nm	26	26	26	26	26	26	26	26	17	
Emergency stop torque (Permissible 1000 times during the lifespan of the gearhead)	T_{2Not}	Nm	100	100	100	100	100	100	100	100	80	
Nominal input speed (At 20 °C ambient temperature) **	n_{1N}	min ⁻¹	4400	4400	4400	4400	4400	4400	4800	5500	5500	
Medial no-load running torque ($n_1=3000$ rpm) (At 20 °C gearhead temperature) ***	T_{012}	Nm	0.5	0.4	0.4	0.3	0.3	0.3	0.2	0.3	0.2	
Maximum input speed	n_{1Max}	min ⁻¹	6000	6000	6000	6000	6000	6000	6000	6000	6000	
Torsional backlash	j_t	arcmin	Standard ≤ 6 / Reduced ≤ 4									
Torsional rigidity	C_{t21}	Nm/arcmin	3.5									
Max. axial force ****	F_{2AMax}	N	2400									
Max. radial force ****	F_{2RMMax}	N	2700									
Max. tilting moment	M_{2KMMax}	Nm	152									
Efficiency at full load	η	%	94									
Service life (For calculation, see alpha Technical Basics catalog)	L_h	h	> 20 000									
Weight incl. adapter plate	m	kg	2.0									
Noise level ($n_1=3000$ rpm) *****	L_{PA}	dB(A)	≤ 64									
Max. permissible housing temperature		°C	+90									
Ambient temperature		°C	0 to +40									
Lubrication			Lubricated for lifetime									
Paint			Blue RAL 5002									
Direction of rotation			Motor and gearhead same direction									
Type of protection			IP 65									
Mass moment of inertia (Referring to the drive)	J_1	kgcm ²	11	0.077	0.069	0.068	0.061	0.061	0.057	0.057	0.056	0.056
Clamping hub diameter (mm)			14	0.17	0.16	0.16	0.16	0.16	0.15	0.15	0.15	0.15

- * Binary ratios (32, 64) available as an option. Consult alpha.
- ** For higher ambient temperature, reduce nominal input speed n_{1N} .
- *** Valid for clamping hub diameter 11 mm.
- **** In reference to the center of the output shaft.
- ***** Measured at ratio $i = 5$ (without load).

Alternative output shaft versions

Keywayed output shaft in mm

E = Key to DIN 6885, page 1, form A

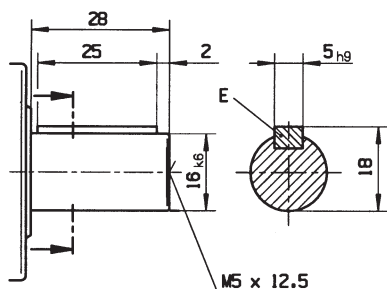

Involute gearing DIN 5480 in mm

X = W 16 x 0.8 x 30 x 18 x 6m, DIN 5480

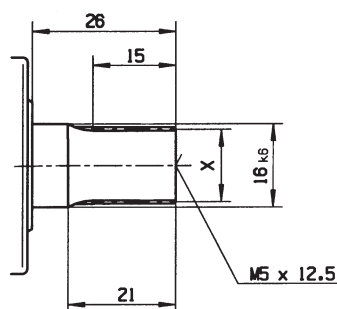

Conversion table

1 mm	= 0.039 in
1 Nm	= 8.85 in.lb
1 kgcm ²	= 8.85 x 10 ⁻⁴ in.lb.s ²
1 N	= 0.225 lb _f
1 kg	= 2.21 lb _m

View A

Motor shaft diameter (mm)

View B

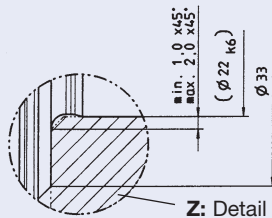
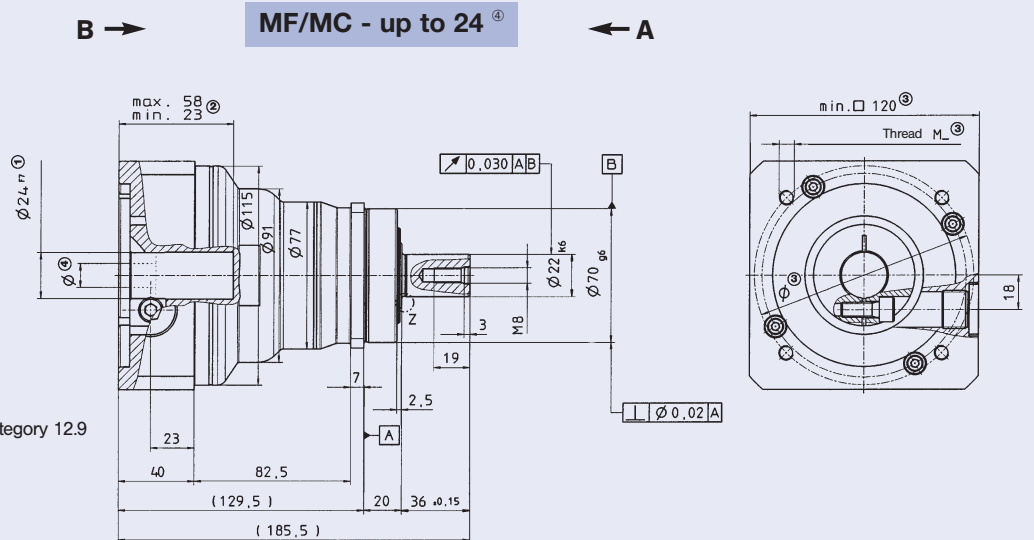
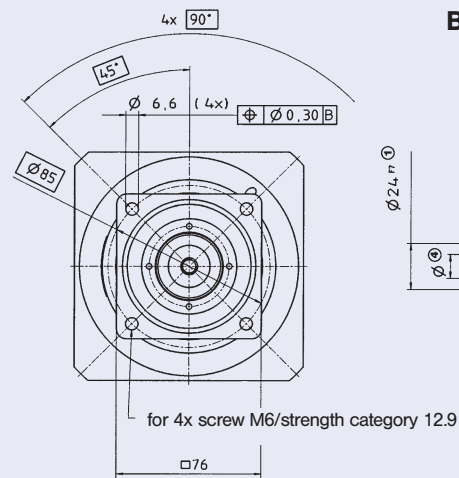
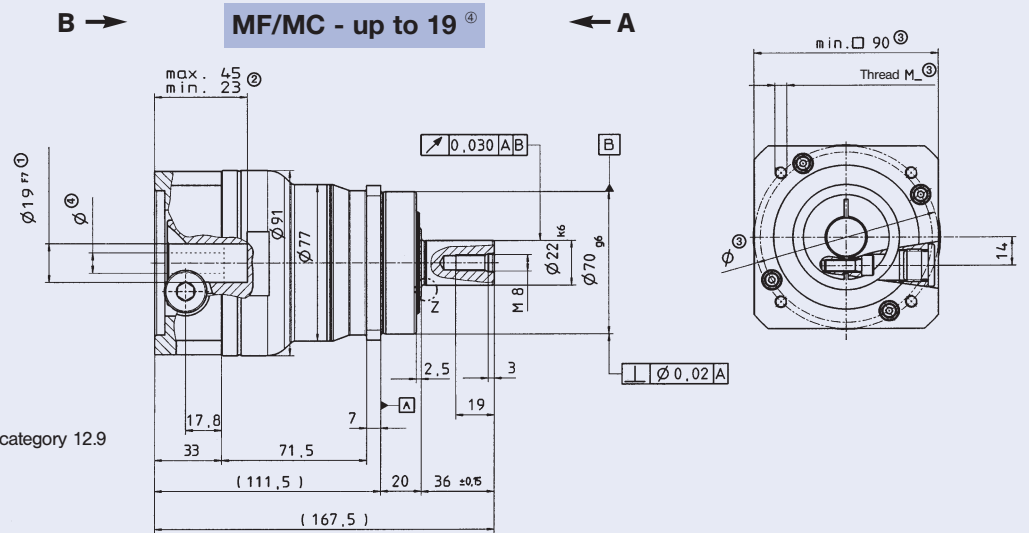
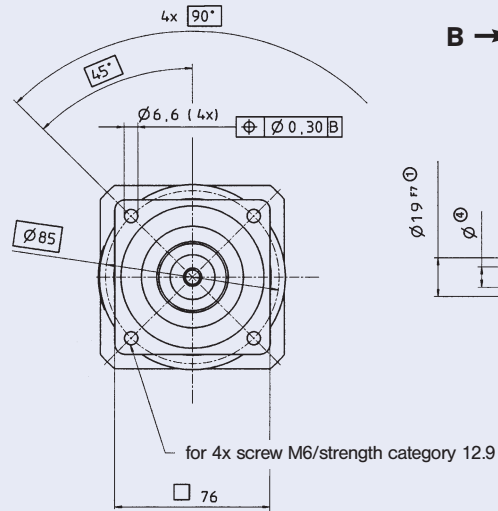
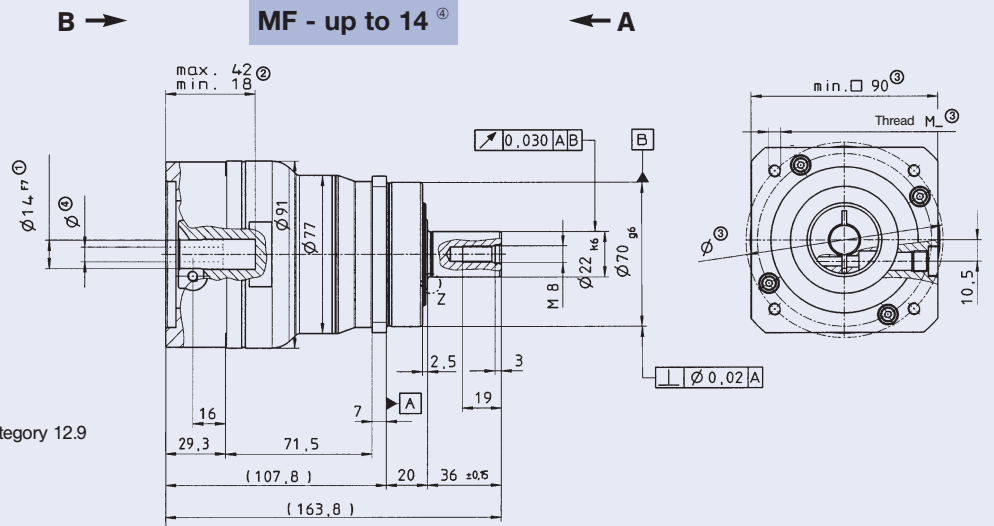
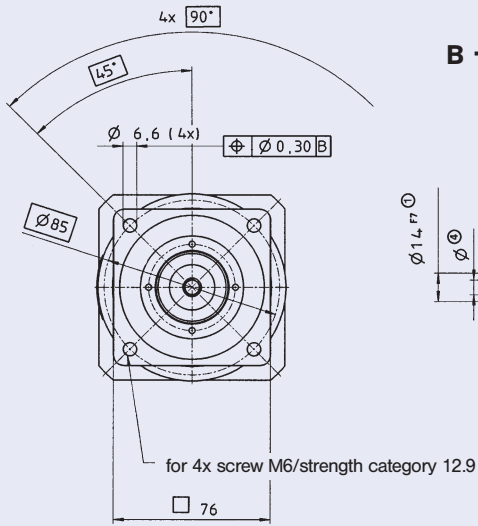

Dimensions without specified tolerances ± 1 mm.

① Check motor shaft fit.

② Min./max. permissible motor shaft length. Longer motor shaft is possible. Please call alpha.

③ The dimensions depend on the motor.

④ Smaller motor shaft diameter is compensated by a bushing with at least 1 mm thickness (see page 34).

⚠ Motor mounting according to operating manual.

MF = Cyclic operation S5
MC = Continuous operation S1

Technical Specifications SP+ 075 1-stage

				1-stage				
Ratio *	i			3	4	5	7	10
Maximum acceleration torque (Max. 1000 cycles per hour)	T_{2B}	Nm	MF	85	110	110	110	90
			MC	42	61	66	66	42
Nominal output torque	T_{2N}	Nm	MF	47	75	75	75	52
			MC	26	39	41	42	26
Emergency stop torque (Permissible 1000 times during the lifespan of the gearhead)	T_{2Not}	Nm		200	250	250	250	200
Nominal input speed (At 20 °C ambient temperature) **	n_{1N}	min ⁻¹	MF	2900	2900	2900	3100	3100
			MC	4500	4500	4500	4500	4500
Medial no-load running torque ($n_1=3000$ rpm) (At 20 °C gearhead temperature) ***	T_{012}	Nm	MF	1.8	1.4	1.1	0.8	0.6
			MC	1.4	1.1	0.9	0.6	0.5
Maximum input speed	n_{1Max}	min ⁻¹		6000	6000	6000	6000	6000
Torsional backlash	j_t	arcmin	MF	Standard ≤ 4 / Reduced ≤ 2				
			MC	Standard ≤ 6 / Reduced ≤ 4				
Torsional rigidity	C_{t21}	Nm/arcmin		10				
Max. axial force ****	F_{2AMax}	N		3350				
Max. radial force ****	F_{2RMax}	N		4000				
Max. tilting moment	M_{2KMax}	Nm		236				
Efficiency at full load	η	%	MF	97				
			MC	98.5				
Service life (For calculation, see alpha Technical Basics catalog)	L_h	h	MF	> 20 000				
			MC	> 30 000				
Weight incl. adapter plate	m	kg		3.9				
Noise level ($n_1=3000$ rpm) *****	L_{PA}	dB(A)		≤ 64				
Max. permissible housing temperature		°C		+90				
Ambient temperature		°C		0 to +40				
Lubrication				Lubricated for lifetime				
Paint				Blue RAL 5002				
Direction of rotation				Motor and gearhead same direction				
Type of protection				IP 65				
Mass moment of inertia (Referring to the drive)	J_1	kgcm ²	14	0.86	0.61	0.51	0.42	0.38
			19	1.03	0.78	0.68	0.59	0.54
			24	2.40	2.15	2.05	1.96	1.91
Clamping hub diameter (mm)								

- * Binary ratios (8) available as an option. Consult alpha.
 ** For higher ambient temperature, reduce nominal input speed n_{1N} .
 *** Valid for clamping hub diameter 19 mm.
 **** In reference to the center of the output shaft.
 ***** Measured at ratio $i = 5$ (without load).

Alternative output shaft versions

Keywayed output shaft in mm

E = Key to DIN 6885, page 1, form A

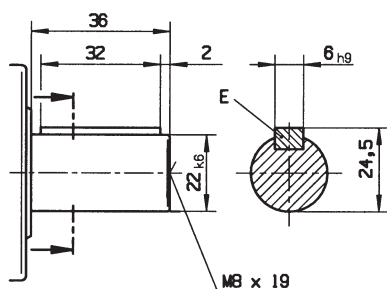

Involute gearing DIN 5480 in mm

X = W 22 x 1.25 x 30 x 16 x 6m, DIN 5480

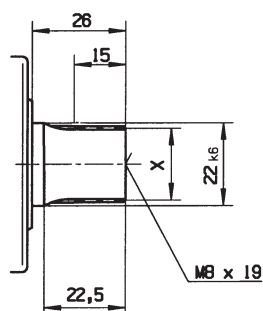

Conversion table

1 mm	= 0.039 in
1 Nm	= 8.85 in.lb
1 kgcm ²	= 8.85 x 10 ⁻⁴ in.lb.s ²
1 N	= 0.225 lb _f
1 kg	= 2.21 lb _m

View A

Motor shaft diameter (mm)

View B

SP+ 075 2-stage

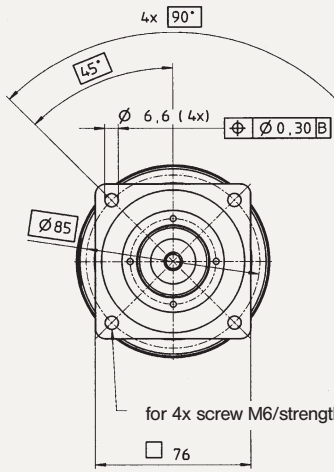

B →

MF - up to 11^④

← A

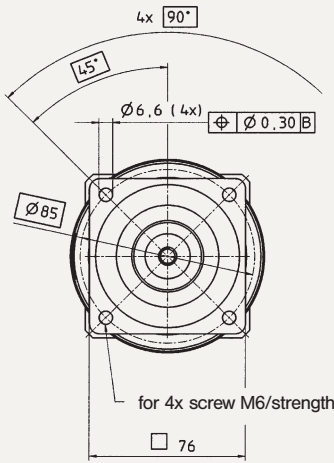
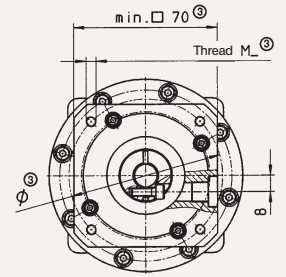
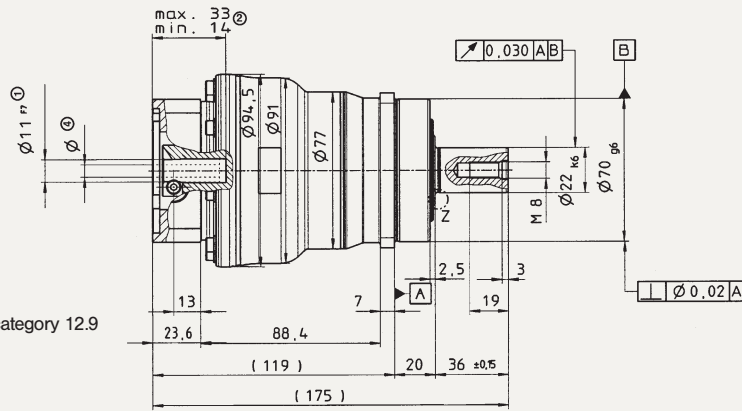

B →

MF/MC - up to 14^④

← A

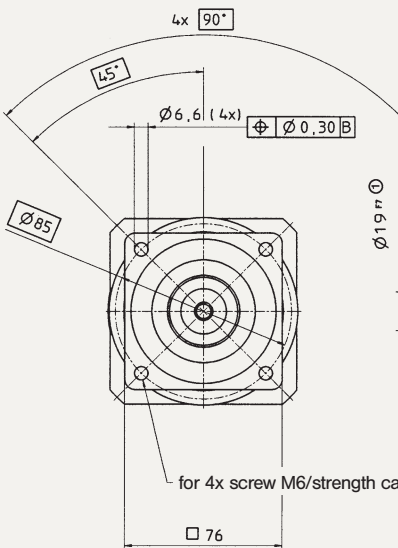
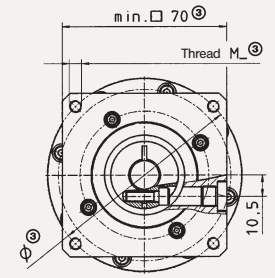
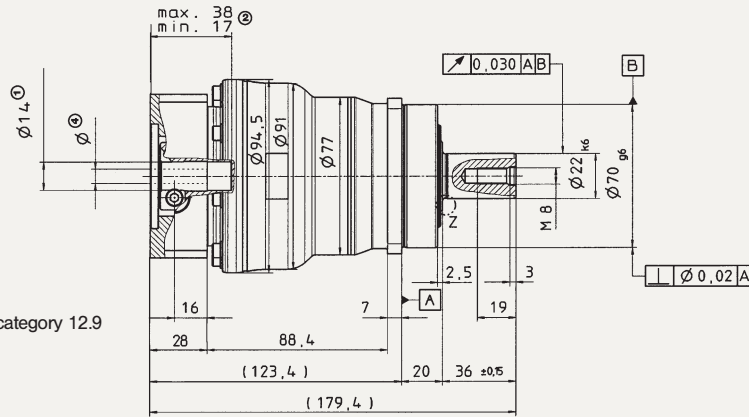

B →

MF/MC - up to 19^④

← A

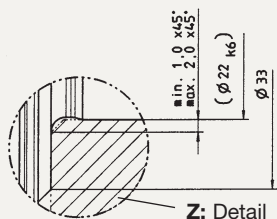
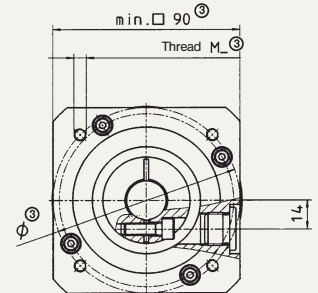
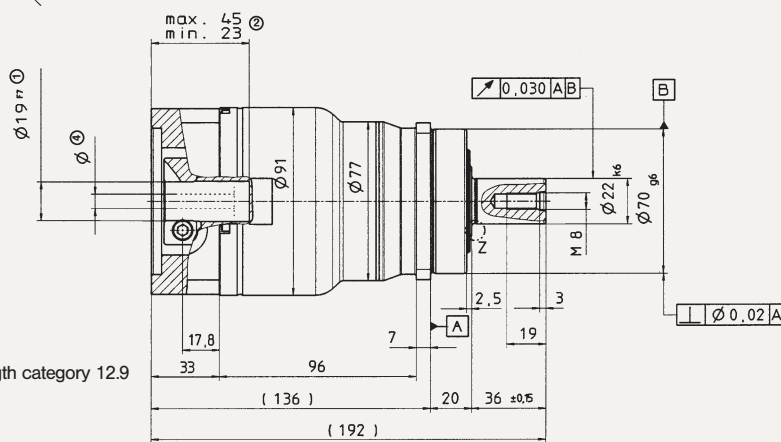

Dimensions without specified tolerances ±1 mm.

① Check motor shaft fit.

② Min./max. permissible motor shaft length. Longer motor shaft is possible. Please call alpha.

③ The dimensions depend on the motor.

④ Smaller motor shaft diameter is compensated by a bushing with at least 1 mm thickness (see page 34).

⚠ Motor mounting according to operating manual.

MF = Cyclic operation S5
MC = Continuous operation S1

Technical Specifications SP+ 075 2-stage

			2-stage									
Ratio *	i		16	20	25	28	35	40	50	70	100	
Maximum acceleration torque (Max. 1000 cycles per hour)	T_{2B}	Nm	MF	110	110	110	110	110	110	110	110	90
			MC	61	66	66	66	66	61	66	66	42
Nominal output torque	T_{2N}	Nm	MF	75	75	75	75	75	75	75	75	52
			MC	39	41	41	42	41	39	41	42	26
Emergency stop torque (Permissible 1000 times during the lifespan of the gearhead)	T_{2Not}	Nm		250	250	250	250	250	250	250	250	200
Nominal input speed (At 20 °C ambient temperature) **	n_{1N}	min ⁻¹	MF	3500	3500	3500	3500	3500	3500	3800	4500	4500
			MC	4500	4500	4500	4500	4500	4500	4500	4500	4500
Medial no-load running torque ($n_1=3000$ rpm) (At 20 °C gearhead temperature) ***	T_{012}	Nm	MF	0.8	0.6	0.6	0.5	0.4	0.4	0.3	0.3	0.3
			MC	0.5	0.4	0.4	0.3	0.3	0.2	0.2	0.2	0.2
Maximum input speed	n_{1Max}	min ⁻¹		6000	6000	6000	6000	6000	6000	6000	6000	6000
Torsional backlash	j_t	arcmin	MF	Standard ≤ 6 / Reduced ≤ 4								
			MC	Standard ≤ 8 / Reduced ≤ 6								
Torsional rigidity	C_{t21}	Nm/arcmin		10								
Max. axial force ****	F_{2AMax}	N		3350								
Max. radial force ****	F_{2RMax}	N		4000								
Max. tilting moment	M_{2KMax}	Nm		236								
Efficiency at full load	η	%	MF	94								
			MC	96.5								
Service life (For calculation, see alpha Technical Basics catalog)	L_h	h	MF	> 20 000								
			MC	> 30 000								
Weight incl. adapter plate	m	kg		3.6								
Noise level ($n_1=3000$ rpm) *****	L_{PA}	dB(A)		≤ 64								
Max. permissible housing temperature		°C		+90								
Ambient temperature		°C		0 to +40								
Lubrication				Lubricated for lifetime								
Paint				Blue RAL 5002								
Direction of rotation				Motor and gearhead same direction								
Type of protection				IP 65								
Mass moment of inertia (Referring to the drive)	J_1	kgcm ²	11	0.16	0.13	0.13	0.10	0.10	0.091	0.090	0.089	0.089
			14	0.23	0.20	0.20	0.18	0.18	0.17	0.16	0.16	0.16
			19	0.55	0.53	0.52	0.50	0.50	0.49	0.49	0.49	0.49

- * Binary ratios (32, 64) available as an option. Consult alpha.
- ** For higher ambient temperature, reduce nominal input speed n_{1N} .
- *** Valid for clamping hub diameter 14 mm.
- **** In reference to the center of the output shaft.
- ***** Measured at ratio $i = 5$ (without load).

Alternative output shaft versions

Keywayed output shaft in mm

E = Key to DIN 6885, page 1, form A

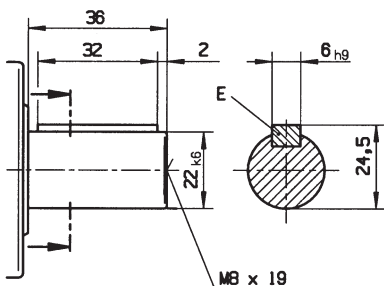

Involute gearing DIN 5480 in mm

X = W 22 x 1.25 x 30 x 16 x 6m, DIN 5480

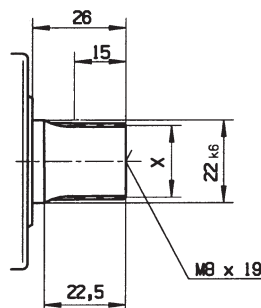

Conversion table

1 mm	= 0.039 in
1 Nm	= 8.85 in.lb
1 kgcm ²	= 8.85 x 10 ⁻⁴ in.lb.s ²
1 N	= 0.225 lb _f
1 kg	= 2.21 lb _m

View A

Motor shaft diameter (mm)

View B

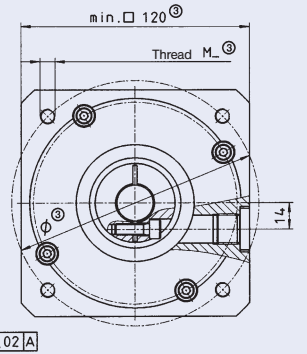
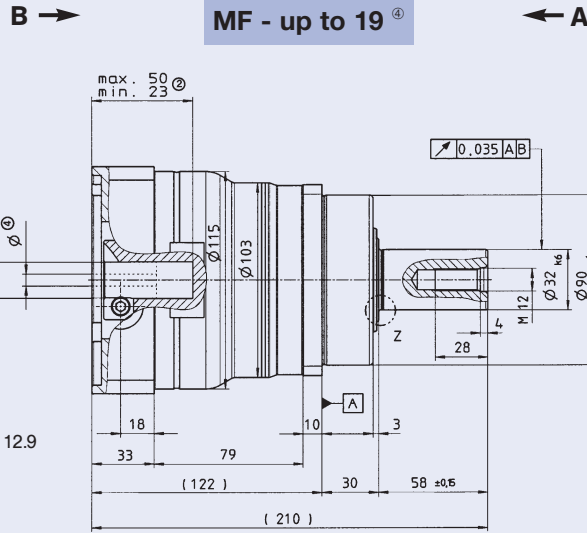
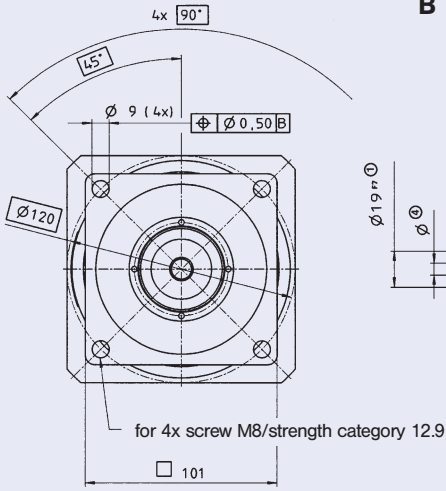

MF - up to 24/28
MC - up to 24

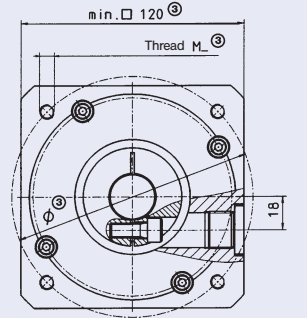
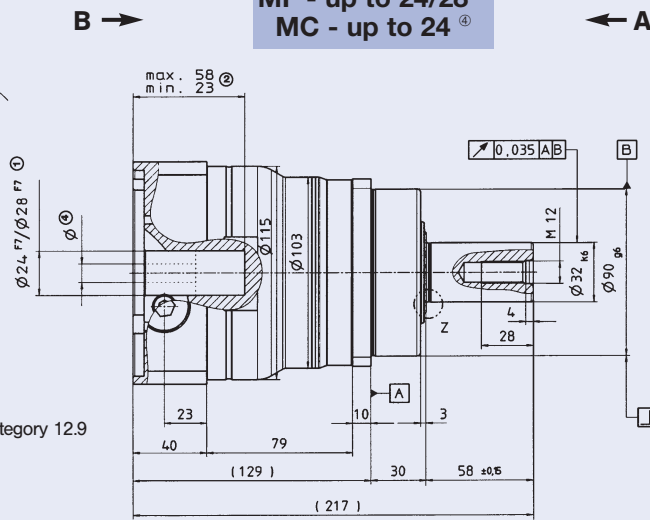
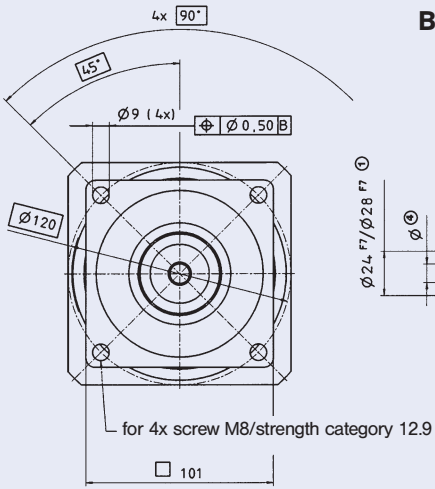

MF/MC - up to 38

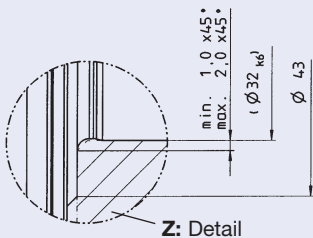
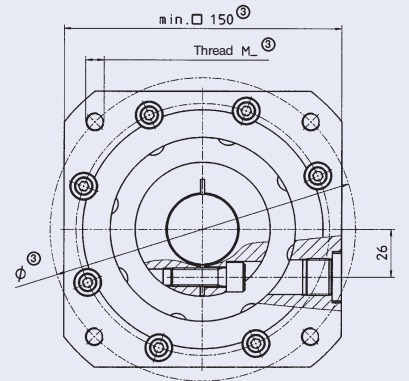
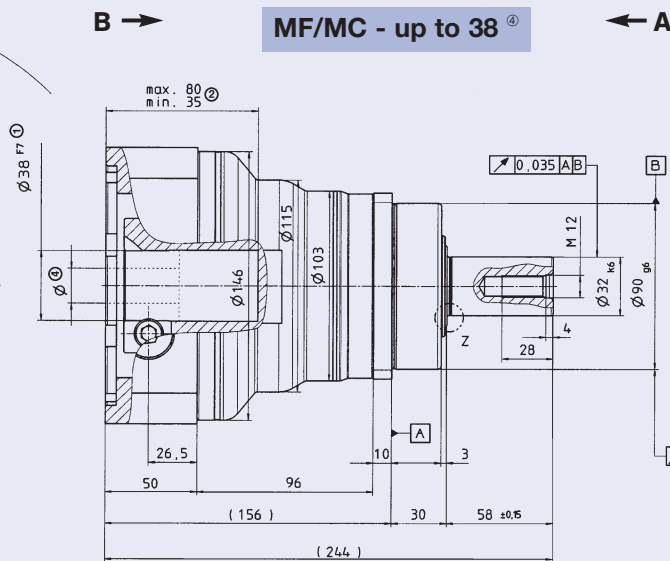
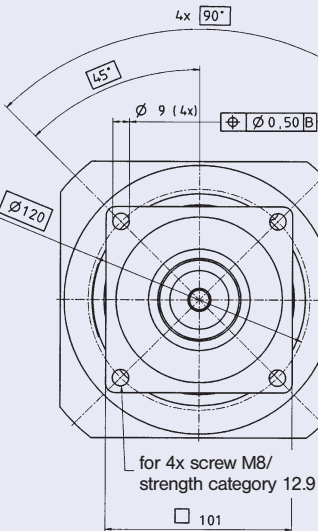

Dimensions without specified tolerances ±1 mm.

① Check motor shaft fit.

② Min./max. permissible motor shaft length. Longer motor shaft is possible. Please call alpha.

③ The dimensions depend on the motor.

④ Smaller motor shaft diameter is compensated by a bushing with at least 1 mm thickness (see page 34).

▲ Motor mounting according to operating manual.

MF = Cyclic operation S5
MC = Continuous operation S1

Technical Specifications SP+ 100 1-stage

			1-stage					
Ratio *	i		3	4	5	7	10	
Maximum acceleration torque (Max. 1000 cycles per hour)	T_{2B}	Nm	MF	225	300	300	300	225
			MC	100	150	160	165	105
Nominal output torque	T_{2N}	Nm	MF	120	180	175	170	120
			MC	65	100	105	105	65
Emergency stop torque (Permissible 1000 times during the lifespan of the gearhead)	T_{2Not}	Nm	500	625	625	625	500	
Nominal input speed (At 20 °C ambient temperature) **	n_{1N}	min ⁻¹	MF	2500	2500	2500	2800	2800
			MC	3500	4000	4500	4500	4500
Medial no-load running torque ($n_1=3000$ rpm) (At 20 °C gearhead temperature) ***	T_{012}	Nm	MF	3.5	2.7	2.4	1.6	1.4
			MC	2.4	2.1	1.8	1.1	0.8
Maximum input speed	n_{1Max}	min ⁻¹	MF	4500	4500	4500	4500	4500
			MC	6000	6000	6000	6000	6000
Torsional backlash	j_t	arcmin	MF	Standard ≤ 3 / Reduced ≤ 1				
			MC	Standard ≤ 4 / Reduced ≤ 2				
Torsional rigidity	C_{t21}	Nm/arcmin	31					
Max. axial force ****	F_{2AMax}	N	5650					
Max. radial force ****	F_{2RMax}	N	6300					
Max. tilting moment	M_{2KMax}	Nm	487					
Efficiency at full load	η	%	MF	97				
			MC	98.5				
Service life (For calculation, see alpha Technical Basics catalog)	L_h	h	MF	> 20 000				
			MC	> 30 000				
Weight incl. adapter plate	m	kg	7.7					
Noise level ($n_1=3000$ rpm) *****	L_{PA}	dB(A)	≤ 66					
Max. permissible housing temperature		°C	+90					
Ambient temperature		°C	0 to +40					
Lubrication			Lubricated for lifetime					
Paint			Blue RAL 5002					
Direction of rotation			Motor and gearhead same direction					
Type of protection			IP 65					
Mass moment of inertia J_1 (Referring to the drive)		kgcm ²	19	3.29	2.35	1.92	1.60	1.38
			24	3.99	3.04	2.61	2.29	2.07
			28	3.01	2.53	2.17	1.89	1.68
			38	11.1	10.1	9.68	9.36	9.14

- * Binary ratios (8) available as an option. Consult alpha.
- ** For higher ambient temperature, reduce nominal input speed n_{1N} .
- *** Valid for clamping hub diameter 24 and 28 mm.
- **** In reference to the center of the output shaft.
- ***** Measured at ratio $i = 5$ (without load).

Alternative output shaft versions

Keywayed output shaft in mm

E = Key to DIN 6885, page 1, form A

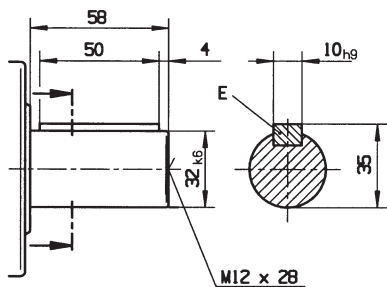

Involute gearing DIN 5480 in mm

X = W 32 x 1.25 x 30 x 24 x 6m, DIN 5480

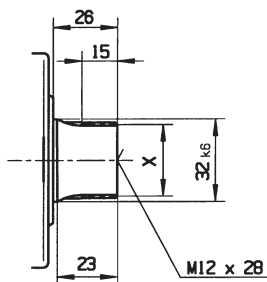

Conversion table

1 mm	= 0.039 in
1 Nm	= 8.85 in.lb
1 kgcm ²	= 8.85 x 10 ⁻⁴ in.lb.s ²
1 N	= 0.225 lb _f
1 kg	= 2.21 lb _m

View A

Motor shaft diameter (mm)

View B

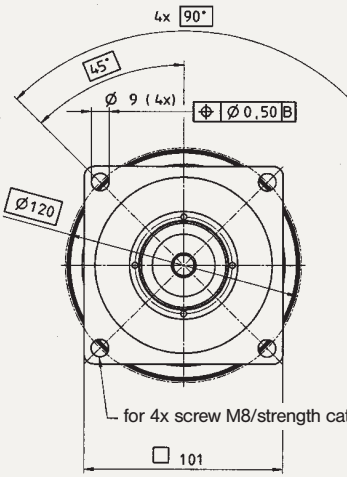

B →

MF - up to 14^④

← A

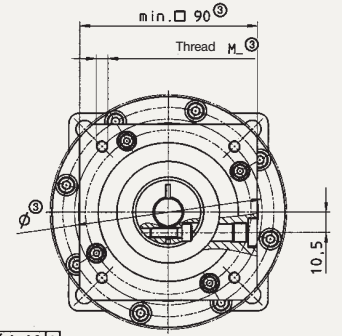
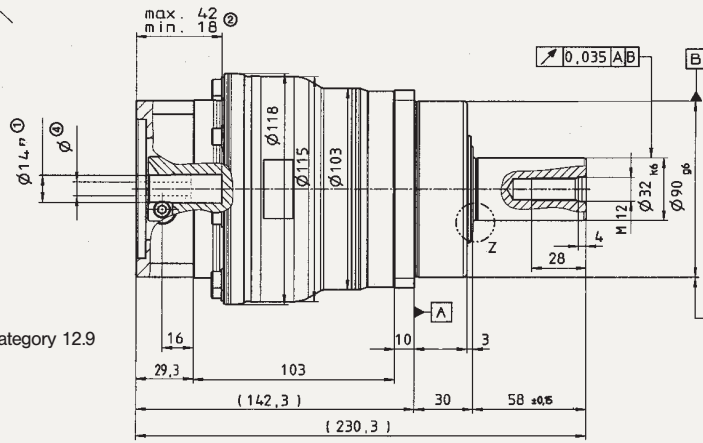

SP+ 100 2-stage

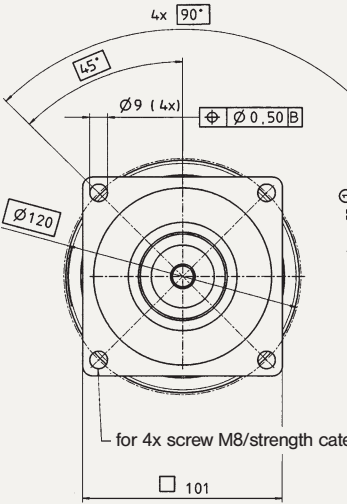

B →

MF/MC - up to 19^④

← A

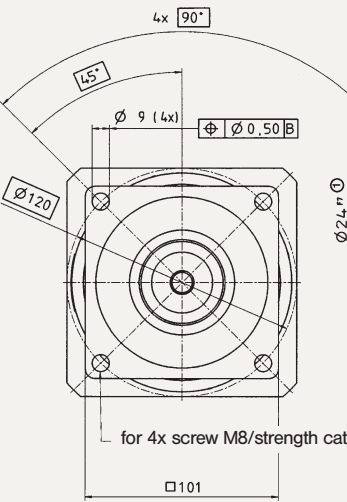
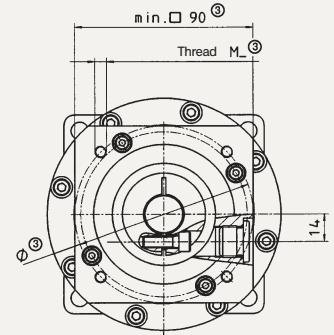
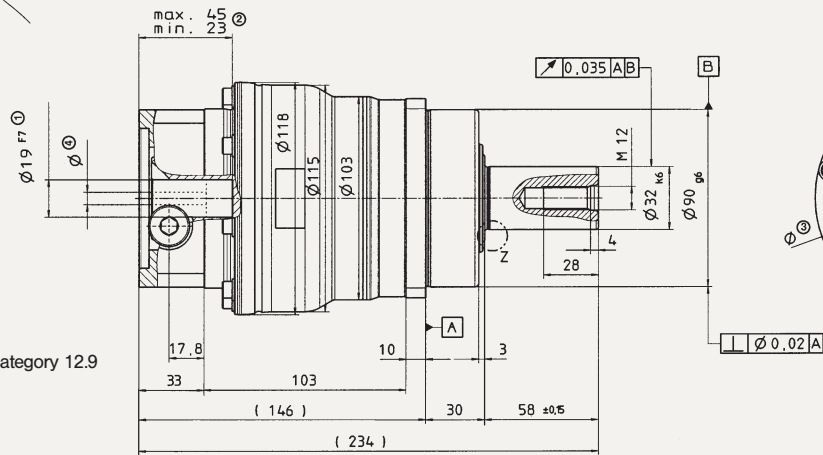

B →

MF/MC - up to 24^④

← A

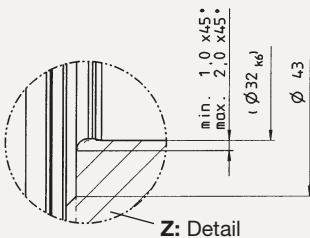
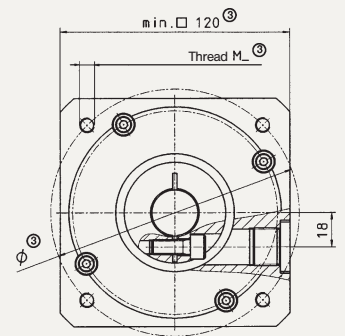
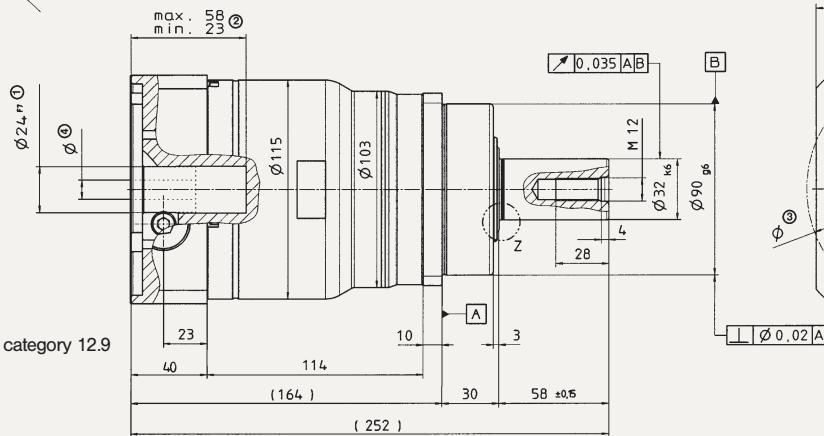

Dimensions without specified tolerances ±1 mm.

- ① Check motor shaft fit.
- ② Min./max. permissible motor shaft length. Longer motor shaft is possible. Please call alpha.
- ③ The dimensions depend on the motor.
- ④ Smaller motor shaft diameter is compensated by a bushing with at least 1 mm thickness (see page 34).

⚠ Motor mounting according to operating manual.

MF = Cyclic operation S5
MC = Continuous operation S1

Technical Specifications SP+ 100 2-stage

			2-stage									
Ratio *	i		16	20	25	28	35	40	50	70	100	
Maximum acceleration torque (Max. 1000 cycles per hour)	T_{2B}	Nm	MF	300	300	300	300	300	300	300	300	225
			MC	150	160	160	165	160	150	160	165	105
Nominal output torque	T_{2N}	Nm	MF	180	180	175	180	175	180	175	170	120
			MC	100	105	105	105	105	100	105	105	65
Emergency stop torque (Permissible 1000 times during the lifespan of the gearhead)	T_{2Not}	Nm	625	625	625	625	625	625	625	625	500	
Nominal input speed (At 20 °C ambient temperature) **	n_{1N}	min ⁻¹	MF	3100	3100	3100	3100	3100	3100	3500	4200	4200
			MC	4500	4500	4500	4500	4500	4500	4500	4500	4500
Medial no-load running torque ($n_1=3000$ rpm) (At 20 °C gearhead temperature) ***	T_{012}	Nm	MF	1.5	1.2	1.1	0.9	0.8	0.7	0.6	0.5	0.5
			MC	0.8	0.7	0.6	0.5	0.4	0.4	0.3	0.3	0.3
Maximum input speed	n_{1Max}	min ⁻¹	MF	4500	4500	4500	4500	4500	4500	4500	4500	4500
			MC	6000	6000	6000	6000	6000	6000	6000	6000	6000
Torsional backlash	j_t	arcmin	MF	Standard ≤ 5 / Reduced ≤ 3								
			MC	Standard ≤ 6 / Reduced ≤ 4								
Torsional rigidity	C_{t21}	Nm/arcmin	31									
Max. axial force ****	F_{2AMax}	N	5650									
Max. radial force ****	F_{2RMax}	N	6300									
Max. tilting moment	M_{2KMMax}	Nm	487									
Efficiency at full load	η	%	MF	94								
			MC	96.5								
Service life (For calculation, see alpha Technical Basics catalog)	L_h	h	MF	> 20 000								
			MC	> 30 000								
Weight incl. adapter plate	m	kg	7.9									
Noise level ($n_1=3000$ rpm) *****	L_{PA}	dB(A)	≤ 66									
Max. permissible housing temperature		°C	+90									
Ambient temperature		°C	0 to +40									
Lubrication			Lubricated for lifetime									
Paint			Blue RAL 5002									
Direction of rotation			Motor and gearhead same direction									
Type of protection			IP 65									
Mass moment of inertia (Referring to the drive)	J_1	kgcm ²	14	0.64	0.54	0.52	0.43	0.43	0.38	0.38	0.37	0.37
			19	0.81	0.70	0.69	0.60	0.59	0.55	0.54	0.54	0.54
			24	2.18	2.07	2.05	1.97	1.96	1.92	1.91	1.91	1.91
Clamping hub diameter (mm)												

* Binary ratios (32, 64) available as an option. Consult alpha.
 ** For higher ambient temperature, reduce nominal input speed n_{1N} .
 *** Valid for clamping hub diameter 19 mm.
 **** In reference to the center of the output shaft.
 ***** Measured at ratio i = 5 (without load).

Alternative output shaft versions

Keyway output shaft in mm
 E = Key to DIN 6885, page 1, form A

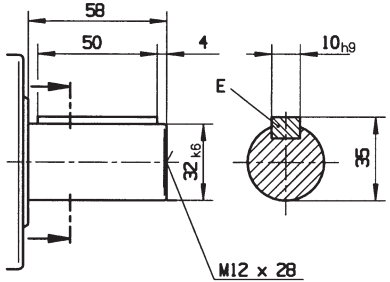

Involute gearing DIN 5480 in mm
 X = W 32 x 1.25 x 30 x 24 x 6m, DIN 5480

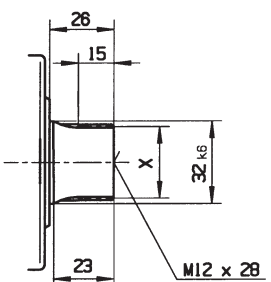

Conversion table

1 mm	= 0.039 in
1 Nm	= 8.85 in.lb
1 kgcm ²	= 8.85 x 10 ⁻⁴ in.lb.s ²
1 N	= 0.225 lb _f
1 kg	= 2.21 lb _m

View A

Motor shaft diameter (mm)

View B

MF - up to 24^④

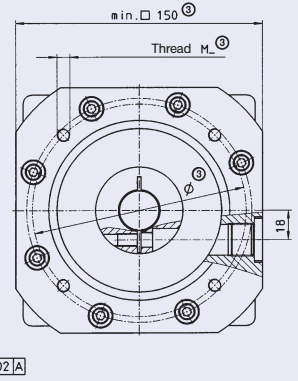
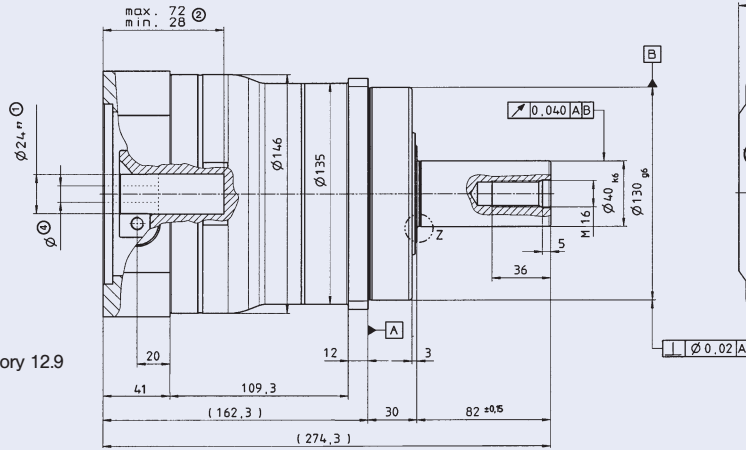
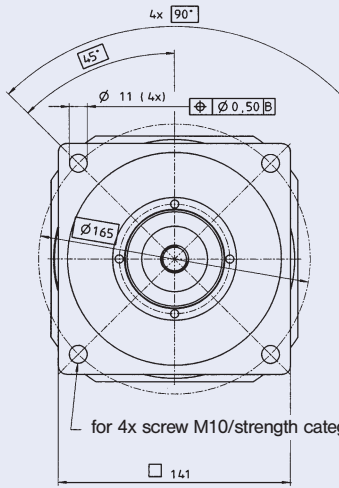

MF - up to 32/38^④
MC - up to 38^④

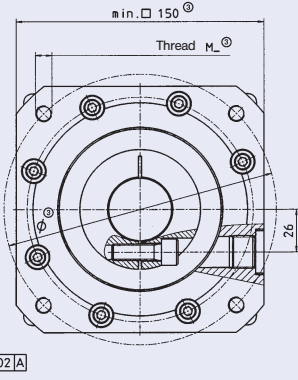
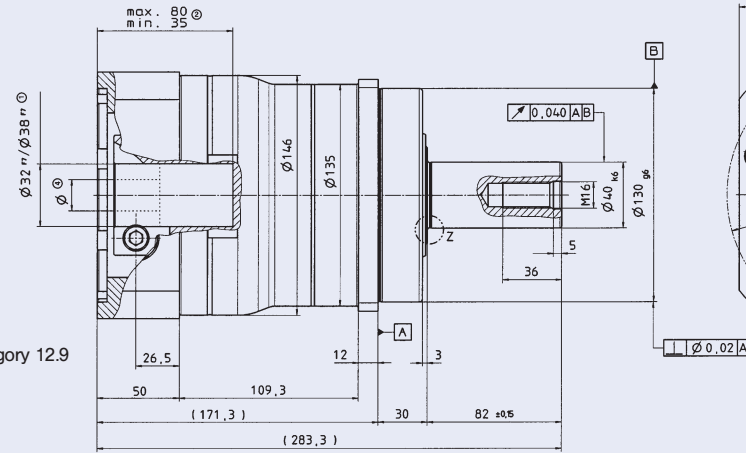
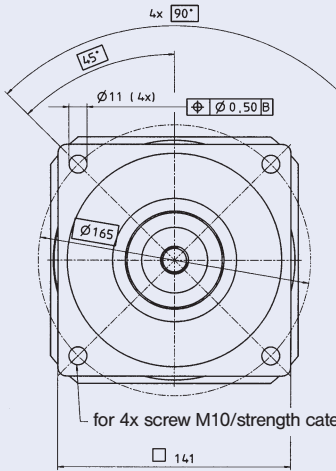

MF - up to 48^④

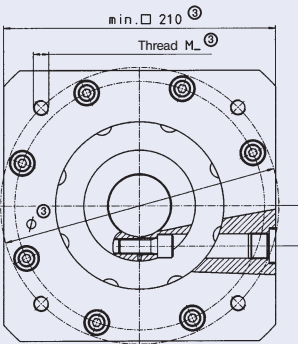
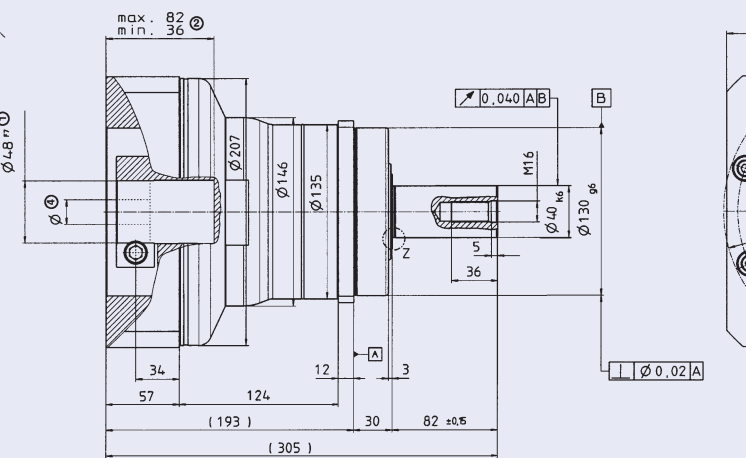
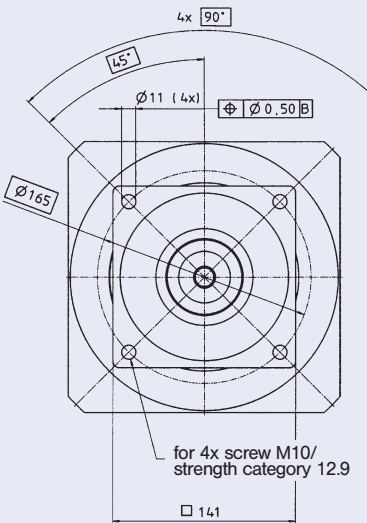

Z: Detail

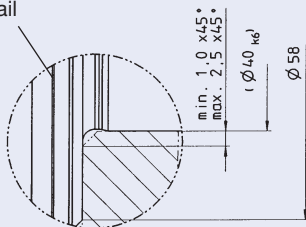

Dimensions without specified tolerances ±1 mm.

- ① Check motor shaft fit.
- ② Min./max. permissible motor shaft length. Longer motor shaft is possible. Please call alpha.
- ③ The dimensions depend on the motor.
- ④ Smaller motor shaft diameter is compensated by a bushing with at least 1 mm thickness (see page 34).

▲ Motor mounting according to operating manual.

MF = Cyclic operation S5
MC = Continuous operation S1

Technical Specifications SP+ 140 1-stage

			1-stage					
Ratio *	i		3	4	5	7	10	
Maximum acceleration torque (Max. 1000 cycles per hour)	T_{2B}	Nm	MF	390	600	600	600	480
			MC	200	230	320	330	195
Nominal output torque	T_{2N}	Nm	MF	200	360	360	360	220
			MC	130	195	205	210	120
Emergency stop torque (Permissible 1000 times during the lifespan of the gearhead)	T_{2Not}	Nm	1000	1250	1250	1250	1000	
Nominal input speed (At 20 °C ambient temperature) **	n_{1N}	min ⁻¹	MF	2100	2100	2100	2600	2600
			MC	3000	3500	4500	4500	4500
Medial no-load running torque ($n_1=3000$ rpm) (At 20 °C gearhead temperature) ***	T_{012}	Nm	MF	7.6	5.8	4.7	3.4	2.5
			MC	5.1	3.9	3.1	2.3	1.6
Maximum input speed	n_{1Max}	min ⁻¹	MF	4000	4000	4000	4000	4000
			MC	6000	6000	6000	6000	6000
Torsional backlash	j_t	arcmin	MF	Standard ≤ 3 / Reduced ≤ 1				
			MC	Standard ≤ 4 / Reduced ≤ 2				
Torsional rigidity	C_{t21}	Nm/arcmin	53					
Max. axial force ****	F_{2AMax}	N	9870					
Max. radial force ****	F_{2RMax}	N	9450					
Max. tilting moment	M_{2KMax}	Nm	952					
Efficiency at full load	η	%	MF	97				
			MC	98.5				
Service life (For calculation, see alpha Technical Basics catalog)	L_h	h	MF	> 20 000				
			MC	> 30 000				
Weight incl. adapter plate	m	kg	17.2					
Noise level ($n_1=3000$ rpm) *****	L_{PA}	dB(A)	≤ 66					
Max. permissible housing temperature		°C	+90					
Ambient temperature		°C	0 to +40					
Lubrication			Lubricated for lifetime					
Paint			Blue RAL 5002					
Direction of rotation			Motor and gearhead same direction					
Type of protection			IP 65					
Mass moment of inertia J_1 (Referring to the drive)		kgcm ²	24	10.7	7.82	6.79	5.84	5.28
			32	13.8	11.0	9.95	9.01	8.44
			38	14.9	12.1	11.0	10.1	9.51
			48	29.5	26.7	25.6	24.7	24.2
Clamping hub diameter (mm)								

* Binary ratios (8) available as an option. Consult alpha.
 ** For higher ambient temperature, reduce nominal input speed n_{1N} .
 *** Valid for clamping hub diameter 32 and 38 mm.
 **** In reference to the center of the output shaft.
 ***** Measured at ratio $i = 5$ (without load).

Alternative output shaft versions

Keywayed output shaft in mm
 E = Key to DIN 6885, page 1, form A

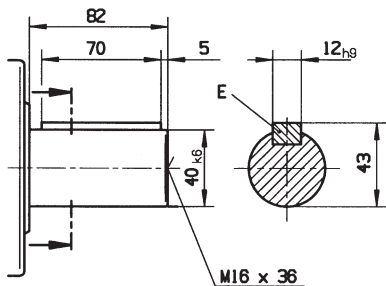

Involute gearing DIN 5480 in mm
 X = W 40 x 2 x 30 x 18 x 6m, DIN 5480

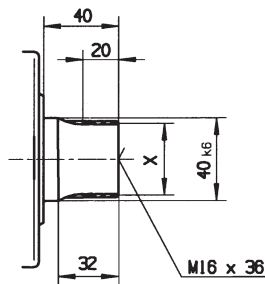

Conversion table

1 mm	= 0.039 in
1 Nm	= 8.85 in.lb
1 kgcm ²	= 8.85 x 10 ⁻⁴ in.lb.s ²
1 N	= 0.225 lb _f
1 kg	= 2.21 lb _m

View A

Motor shaft diameter (mm)

View B

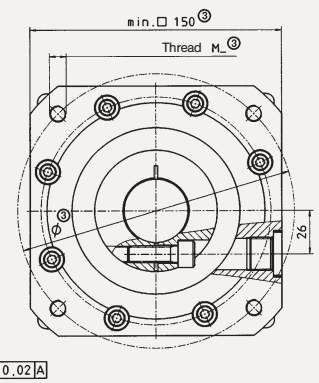
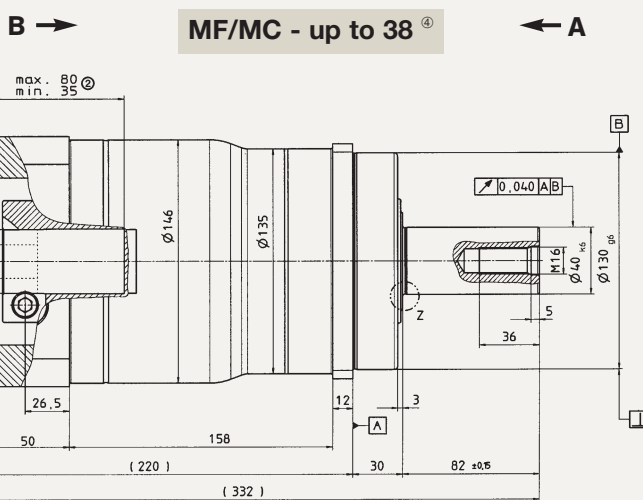
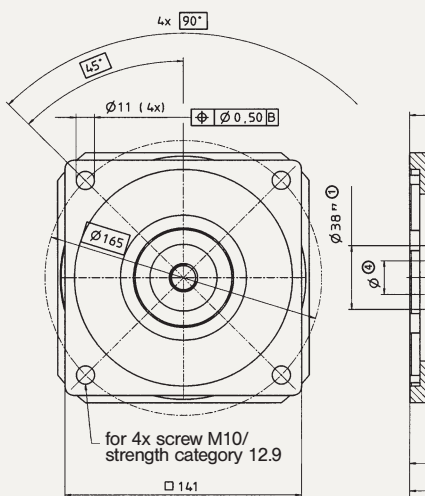
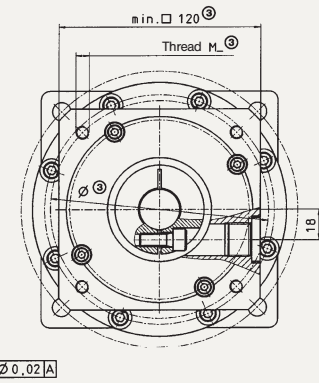
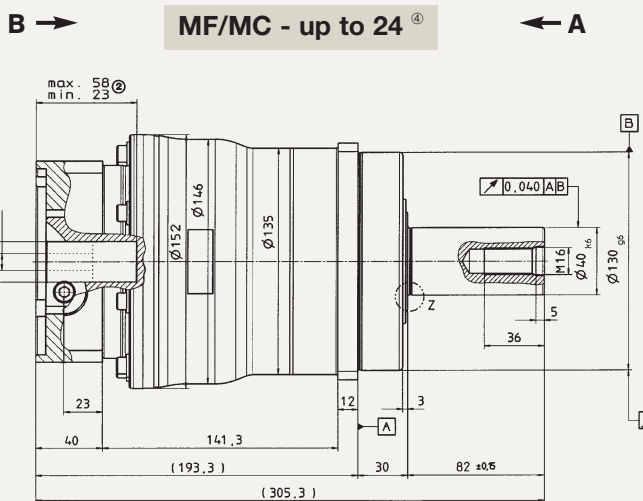
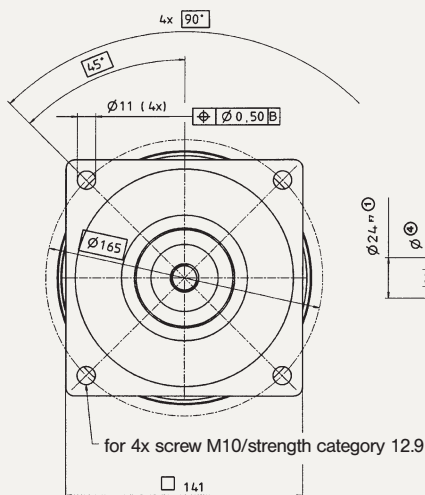
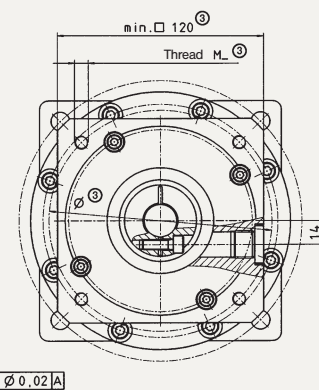
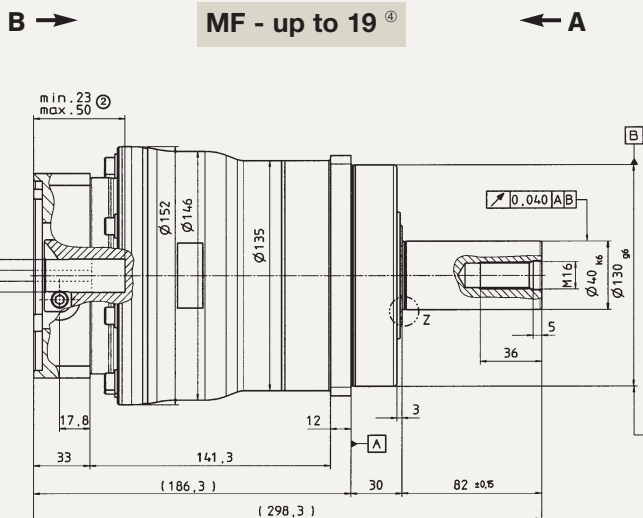
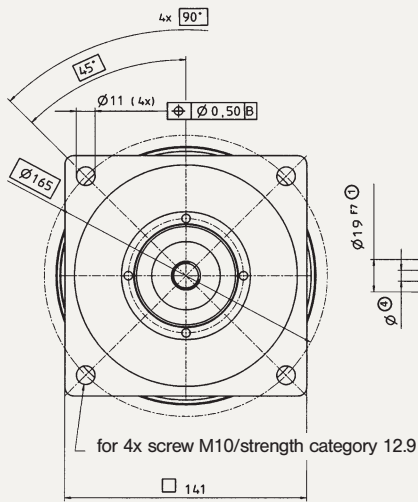

Z: Detail

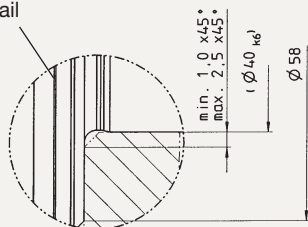

Dimensions without specified tolerances ±1 mm.

- ① Check motor shaft fit.
- ② Min./max. permissible motor shaft length. Longer motor shaft is possible. Please call alpha.
- ③ The dimensions depend on the motor.
- ④ Smaller motor shaft diameter is compensated by a bushing with at least 1 mm thickness (see page 34).

▲ Motor mounting according to operating manual.

MF = Cyclic operation S5
MC = Continuous operation S1

Technical Specifications **SP+ 140** 2-stage

			2-stufig									
Ratio *	i		16	20	25	28	35	40	50	70	100	
Maximum acceleration torque (Max. 1000 cycles per hour)	T_{2B}	Nm	MF	600	600	600	600	600	600	600	600	480
			MC	230	320	320	330	320	230	320	330	195
Nominal output torque	T_{2N}	Nm	MF	360	360	360	360	360	360	360	360	220
			MC	195	205	205	210	205	195	205	210	120
Emergency stop torque (Permissible 1000 times during the lifespan of the gearhead)	T_{2Not}	Nm	1250	1250	1250	1250	1250	1250	1250	1250	1000	
Nominal input speed (At 20 °C ambient temperature) **	n_{1N}	min ⁻¹	MF	2900	2900	2900	2900	2900	2900	3200	3200	3900
			MC	4500	4500	4500	4500	4500	4500	4500	4500	4500
Medial no-load running torque ($n_1=3000$ rpm) (At 20 °C gearhead temperature) ***	T_{012}	Nm	MF	3.3	2.7	2.4	1.9	1.8	1.4	1.3	1.2	1.1
			MC	1.6	1.3	1.2	1.0	0.9	0.7	0.6	0.5	0.5
Maximum input speed	n_{1Max}	min ⁻¹	MF	4000	4000	4000	4000	4000	4000	4000	4000	4000
			MC	6000	6000	6000	6000	6000	6000	6000	6000	6000
Torsional backlash	j_t	arcmin	MF	Standard ≤ 5 / Reduced ≤ 3								
			MC	Standard ≤ 6 / Reduced ≤ 4								
Torsional rigidity	C_{t21}	Nm/arcmin	53									
Max. axial force ****	F_{2AMax}	N	9870									
Max. radial force ****	F_{2RMax}	N	9450									
Max. tilting moment	M_{2KMax}	Nm	952									
Efficiency at full load	η	%	MF	94								
			MC	96.5								
Service life (For calculation, see alpha Technical Basics catalog)	L_h	h	MF	> 20 000								
			MC	> 30 000								
Weight incl. adapter plate	m	kg	17									
Noise level ($n_1=3000$ rpm) *****	L_{PA}	dB(A)	≤ 66									
Max. permissible housing temperature		°C	+90									
Ambient temperature		°C	0 to +40									
Lubrication	Lubricated for lifetime											
Paint	Blue RAL 5002											
Direction of rotation	Motor and gearhead same direction											
Type of protection	IP 65											
Mass moment of inertia (Referring to the drive)	J_1	kgcm ²	19	2.50	2.01	1.97	1.65	1.63	1.40	1.39	1.38	1.38
			24	3.19	2.71	2.67	2.34	2.32	2.10	2.08	2.08	2.07
Clamping hub diameter (mm)			38	10.3	9.77	9.73	9.41	9.39	9.16	9.15	9.14	9.14

- * Binary ratios (32, 64) available as an option. Consult alpha.
 ** For higher ambient temperature, reduce nominal input speed n_{1N} .
 *** Valid for clamping hub diameter 24 mm.
 **** In reference to the center of the output shaft.
 ***** Measured at ratio $i = 5$ (without load).

Alternative output shaft versions

Keywayed output shaft in mm

E = Key to DIN 6885, page 1, form A

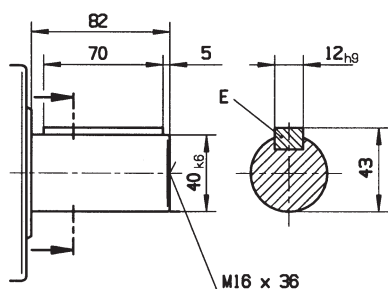

Involute gearing DIN 5480 in mm

X = W 40 x 2 x 30 x 18 x 6m, DIN 5480

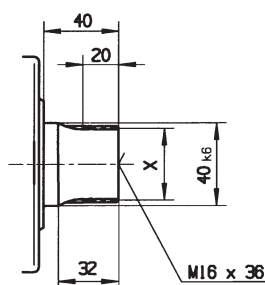

Conversion table

1 mm	= 0.039 in
1 Nm	= 8.85 in.lb
1 kgcm ²	= 8.85 x 10 ⁻⁴ in.lb.s ²
1 N	= 0.225 lb _f
1 kg	= 2.21 lb _m

View A

Motor shaft diameter (mm)

View B

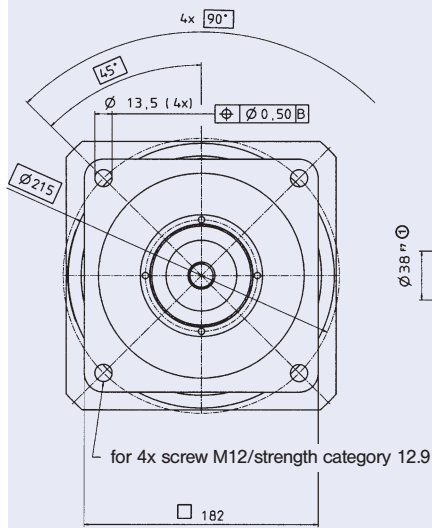

B →

MF - up to 38^④

← A

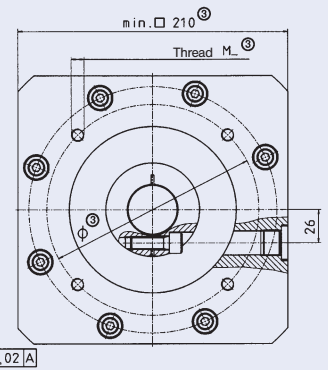
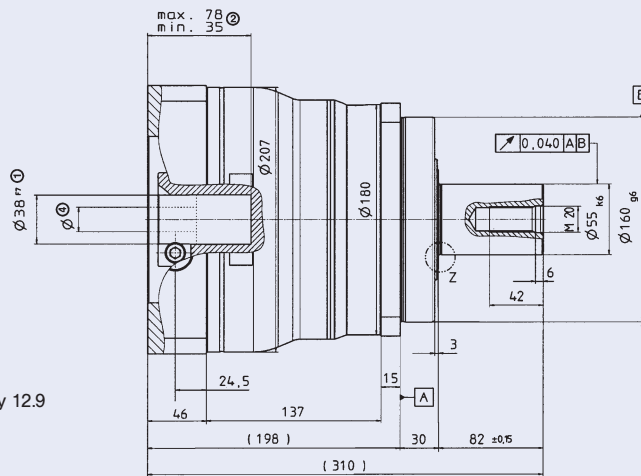

B →

MF/MC - up to 48^④

← A

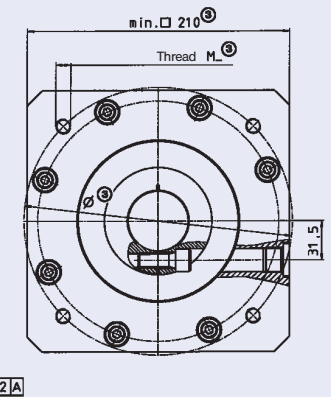
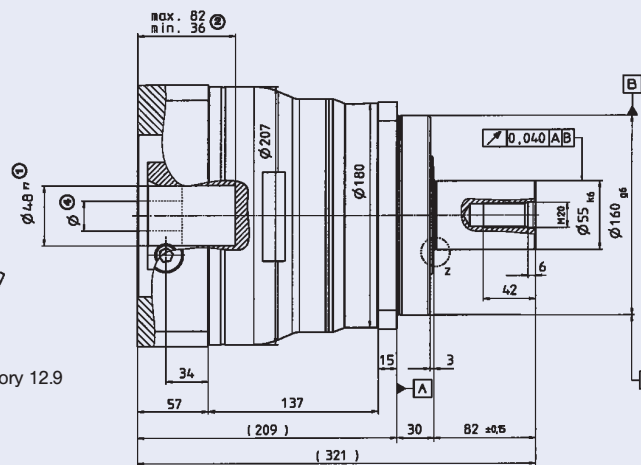
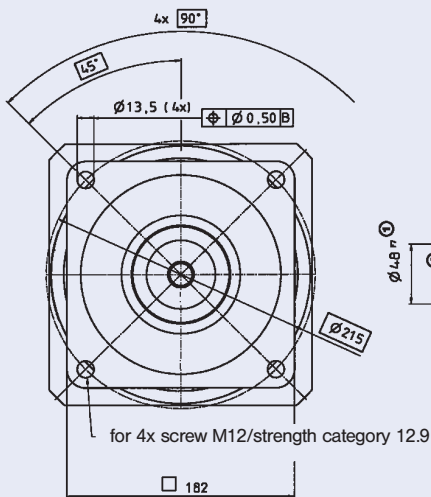

Z: Detail

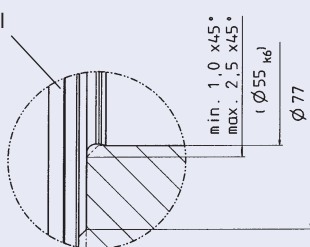

Dimensions without specified tolerances ± 1 mm.

- ① Check motor shaft fit.
- ② Min./max. permissible motor shaft length. Longer motor shaft is possible. Please call alpha.
- ③ The dimensions depend on the motor.
- ④ Smaller motor shaft diameter is compensated by a bushing with at least 1 mm thickness (see page 34).

⚠ Motor mounting according to operating manual.

MF = Cyclic operation S5
MC = Continuous operation S1

Technical Specifications SP+ 180 1-stage

				1-stage				
Ratio *	i			3	4	5	7	10
Maximum acceleration torque (Max. 1000 cycles per hour)	T_{2B}	Nm	MF	880	1100	1100	1100	880
			MC	275	410	430	450	485
Nominal output torque	T_{2N}	Nm	MF	530	750	750	750	750
			MC	170	255	270	275	305
Emergency stop torque (Permissible 1000 times during the lifespan of the gearhead)	T_{2Not}	Nm		2200	2750	2750	2750	2200
Nominal input speed (At 20 °C ambient temperature) **	n_{1N}	min ⁻¹	MF	1500	1500	1500	2300	2300
			MC	3000	3500	4500	4500	4500
Medial no-load running torque ($n_1=3000$ rpm) (At 20 °C gearhead temperature) ***	T_{012}	Nm	MF	14.0	11.0	9.0	6.8	5.0
			MC	10.2	7.7	6.2	4.5	3.2
Maximum input speed	n_{1Max}	min ⁻¹	MF	3500	3500	3500	3500	3500
			MC	4500	6000	6000	6000	6000
Torsional backlash	j_t	arcmin	MF	Standard ≤ 3 / Reduced ≤ 1				
			MC	Standard ≤ 4 / Reduced ≤ 2				
Torsional rigidity	C_{t21}	Nm/arcmin		175				
Max. axial force ****	F_{2AMax}	N		14 150				
Max. radial force ****	F_{2RMax}	N		14 700				
Max. tilting moment	M_{2KMax}	Nm		1600				
Efficiency at full load	η	%	MF	97				
			MC	98.5				
Service life (For calculation, see alpha Technical Basics catalog)	L_h	h	MF	> 20 000				
			MC	> 30 000				
Weight incl. adapter plate	m	kg		34				
Noise level ($n_1=3000$ rpm) *****	L_{PA}	dB(A)		≤ 66				
Max. permissible housing temperature		°C		+90				
Ambient temperature		°C		0 to +40				
Lubrication				Lubricated for lifetime				
Paint				Blue RAL 5002				
Direction of rotation				Motor and gearhead same direction				
Type of protection				IP 65				
Mass moment of inertia (Referring to the drive)	J_1	kgcm ²	38	50.8	33.9	27.9	22.2	19.2
			48	58.2	41.2	35.3	29.6	26.5
Clamping hub diameter (mm)				58.2	41.2	35.3	29.6	26.5

- * Binary ratios (8) available as an option. Consult alpha.
** For higher ambient temperature, reduce nominal input speed n_{1N} .
*** Valid for clamping hub diameter 48 mm.
**** In reference to the center of the output shaft.
***** Measured at ratio $i=5$ (without load).

Alternative output shaft versions

Keywayed output shaft in mm

E = Key to DIN 6885, page 1, form A

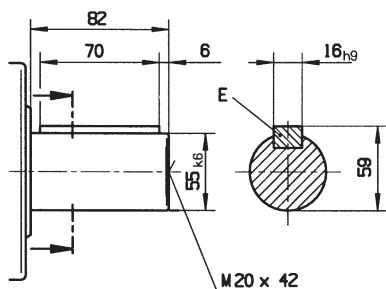

Involute gearing DIN 5480 in mm

X = W 55 x 2 x 30 x 26 x 6m, DIN 5480

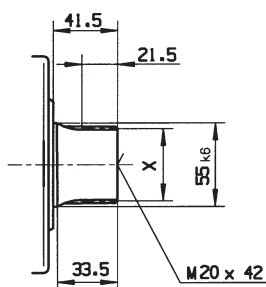

Conversion table

1 mm	= 0.039 in
1 Nm	= 8.85 in.lb
1 kgcm ²	= 8.85 x 10 ⁻⁴ in.lb.s ²
1 N	= 0.225 lb _f
1 kg	= 2.21 lb _m

View A

Motor shaft diameter (mm)

View B

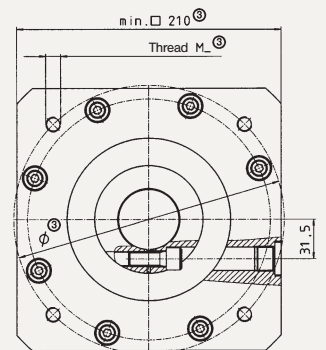
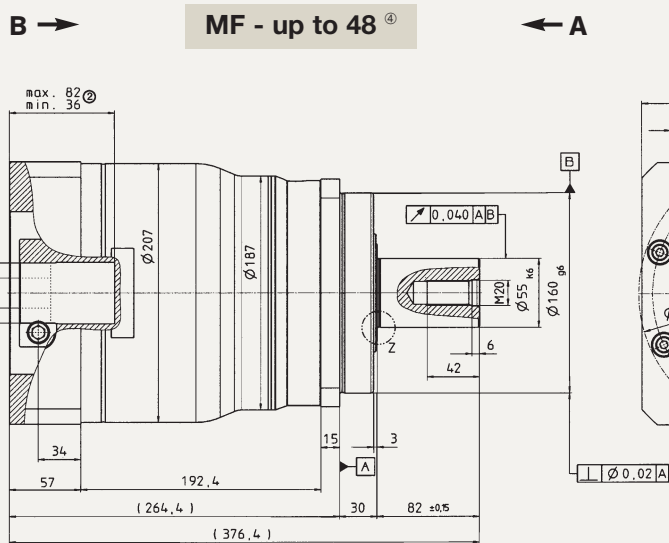
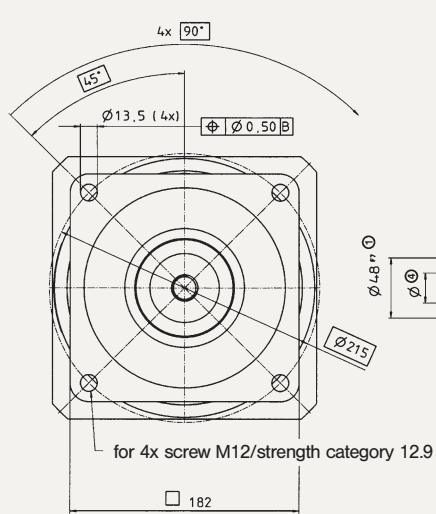
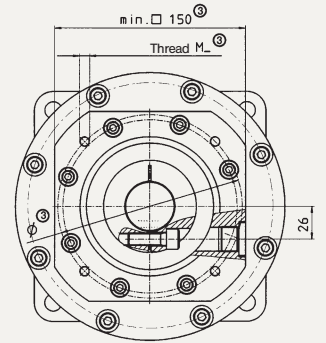
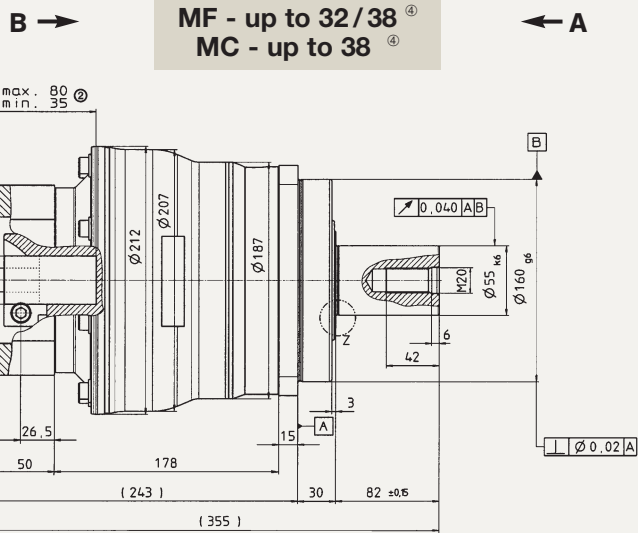
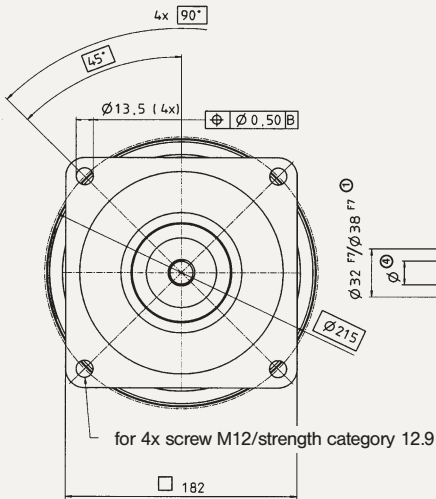
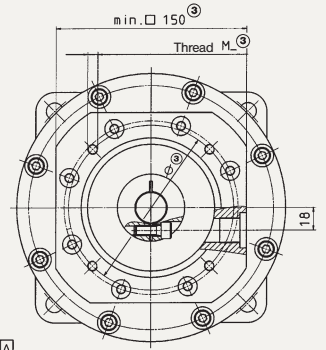
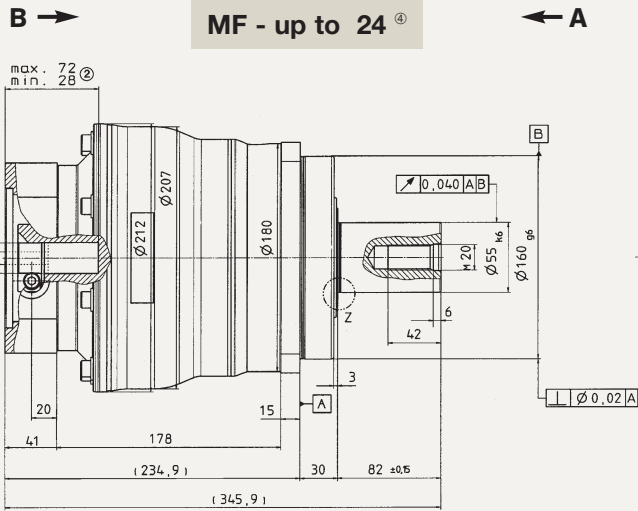
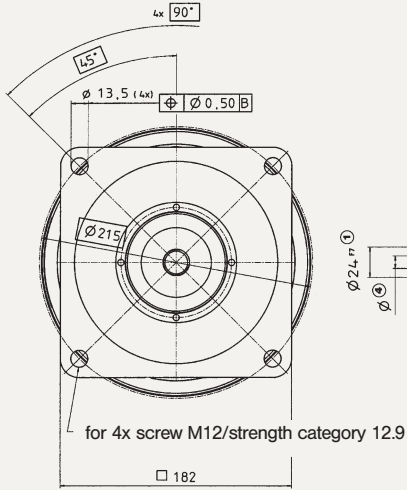

Z: Detail

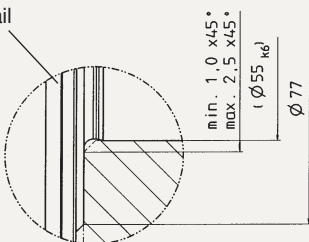

Dimensions without specified tolerances ±1 mm.

- ① Check motor shaft fit.
- ② Min./max. permissible motor shaft length. Longer motor shaft is possible. Please call alpha.
- ③ The dimensions depend on the motor.
- ④ Smaller motor shaft diameter is compensated by a bushing with at least 1 mm thickness (see page 34).

▲ Motor mounting according to operating manual.

MF = Cyclic operation S5
MC = Continuous operation S1

Technical Specifications SP+ 180 2-stage

			2-stage									
Ratio *	i		16	20	25	28	35	40	50	70	100	
Maximum acceleration torque (Max. 1000 cycles per hour)	T _{2B}	Nm	MF	1100	1100	1100	1100	1100	1100	1100	1100	880
			MC	410	430	430	450	430	410	430	450	485
Nominal output torque	T _{2N}	Nm	MF	750	750	750	750	750	750	750	750	750
			MC	255	270	270	275	270	255	270	275	305
Emergency stop torque (Permissible 1000 times during the lifespan of the gearhead)	T _{2Not}	Nm		2750	2750	2750	2750	2750	2750	2750	2750	2200
Nominal input speed (At 20 °C ambient temperature) **	n _{1N}	min ⁻¹	MF	2700	2700	2700	2700	2700	2700	2900	3200	3400
			MC	4500	4500	4500	4500	4500	4500	4500	4500	4500
Medial no-load running torque (n ₁ =3000 rpm) (At 20 °C gearhead temperature) ***	T ₀₁₂	Nm	MF	2.9	2.7	2.5	2.3	2.0	1.8	1.7	1.5	1.3
			MC	0.5	0.5	0.5	0.5	0.5	0.5	0.5	0.5	0.5
Maximum input speed	n _{1Max}	min ⁻¹	MF	4000	4000	4000	4000	4000	4000	4000	4000	4000
			MC	6000	6000	6000	6000	6000	6000	6000	6000	6000
Torsional backlash	j _t	arcmin	MF	Standard ≤ 5 / Reduced ≤ 3								
			MC	Standard ≤ 6 / Reduced ≤ 4								
Torsional rigidity	C _{t21}	Nm/arcmin	175									
Max. axial force ****	F _{2AMax}	N	14 150									
Max. radial force ****	F _{2RMax}	N	14 700									
Max. tilting moment	M _{2KMax}	Nm	1600									
Efficiency at full load	η	%	MF	94								
			MC	96.5								
Service life (For calculation, see alpha Technical Basics catalog)	L _h	h	MF	> 20 000								
			MC	> 30 000								
Weight incl. adapter plate	m	kg	36.4									
Noise level (n ₁ =3000 rpm) *****	L _{PA}	dB(A)	≤ 66									
Max. permissible housing temperature		°C	+90									
Ambient temperature		°C	0 to +40									
Lubrication	Lubricated for lifetime											
Paint	Blue RAL 5002											
Direction of rotation	Motor and gearhead same direction											
Type of protection	IP 65											
Mass moment of inertia (Referring to the drive)	J ₁	kgcm ²	24	9.27	7.72	7.48	6.32	6.20	5.51	5.45	5.39	5.36
			32	12.4	10.9	10.6	9.48	9.36	8.67	8.61	8.55	8.52
			38	13.5	12.0	11.7	10.6	10.4	9.74	9.68	9.63	9.60
			48	28.1	26.6	26.3	25.2	25.1	24.4	24.3	24.3	24.3
Clamping hub diameter (mm)			24	32	38	48						

* Binary ratios (32, 64) available as an option. Consult alpha.
 ** For higher ambient temperature, reduce nominal input speed n_{1N}.
 *** Valid for clamping hub diameter 32 and 38 mm.
 **** In reference to the center of the output shaft.
 ***** Measured at ratio i = 5 (without load).

Alternative output shaft versions

Keywayed output shaft in mm

E = Key to DIN 6885, page 1, form A

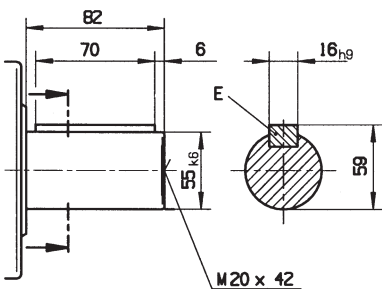

Involute gearing DIN 5480 in mm

X = W 55 x 2 x 30 x 26 x 6m, DIN 5480

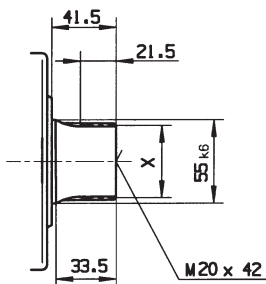

Conversion table

1 mm	= 0.039 in
1 Nm	= 8.85 in.lb
1 kgcm ²	= 8.85 x 10 ⁻⁴ in.lb.s ²
1 N	= 0.225 lb _f
1 kg	= 2.21 lb _m

View A

Motor shaft diameter (mm)

View B

1-stage

MF/MC bis 55^④

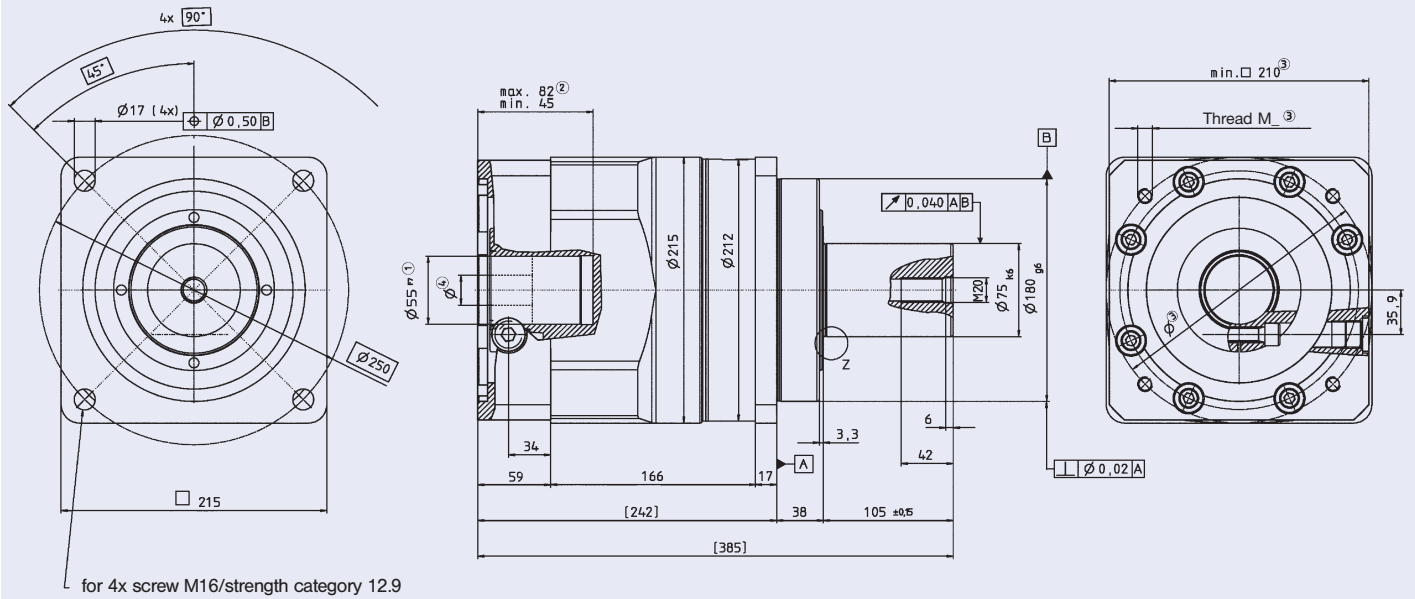

2-stage

MF/MC bis 48^④

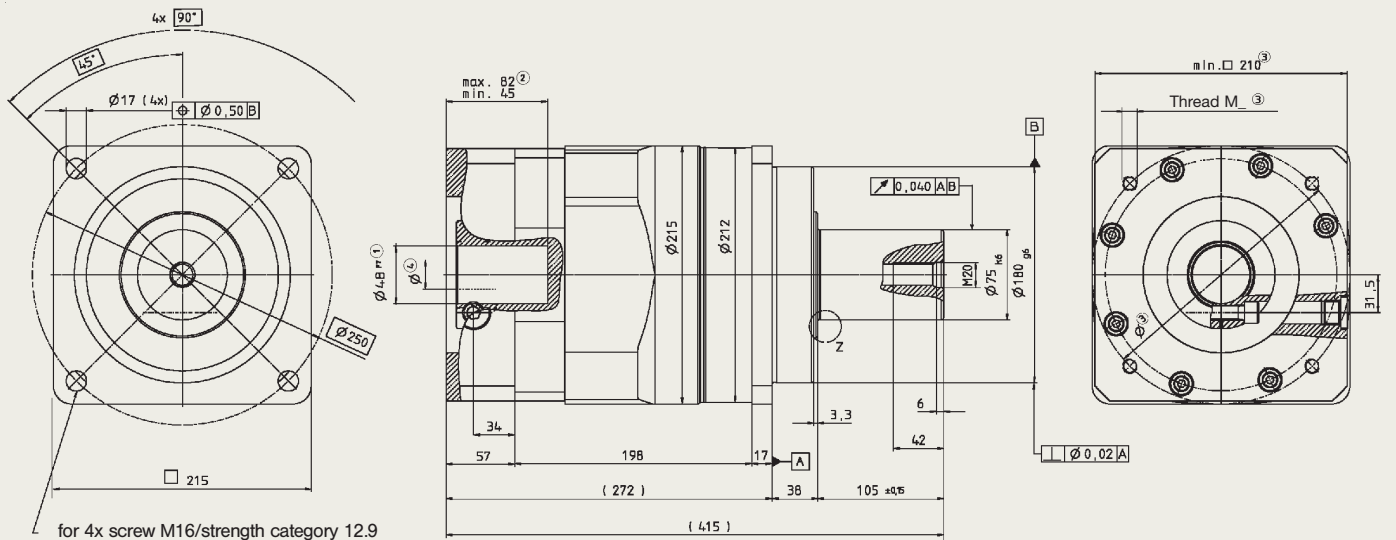

Z: Detail

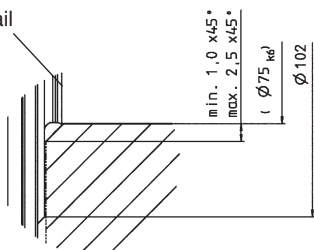

Dimensions without specified tolerances ± 1 mm.

- ① Check motor shaft fit.
- ② Min./max. permissible motor shaft length. Longer motor shaft is possible. Please call alpha.
- ③ The dimensions depend on the motor.
- ④ Smaller motor shaft diameter is compensated by a bushing with at least 1 mm thickness (see page 34).

▲ Motor mounting according to operating manual.

Technical Specifications SP+ 210

			1-stage					2-stage									
Ratio	i		3	4	5	7	10	16	20	25	28	35	40	50	70	100	
Maximum acceleration torque (Max. 1000 cycles per hour)	T_{2B}	Nm	MF	1600	2500	2500	2400	1900	2400	2500	2500	2400	2400	2400	2400	2400	1900
			MC	530	820	860	900	1000	820	860	860	900	860	820	860	900	1000
Nominal output torque	T_{2N}	Nm	MF	1100	1500	1500	1400	1000	1500	1500	1500	1500	1500	1500	1500	1400	1000
			MC	340	510	550	560	630	510	550	550	560	550	510	550	560	630
Emergency stop torque (Permissible 1000 times during the lifespan of the gearhead)	T_{2Not}	Nm		5000	5200	5200	5200	5000	5200	5200	5200	5200	5200	5200	5200	5200	5000
Nominal input speed (At 20 °C ambient temperature) *	n_{1N}	min ⁻¹	MF	1200	1200	1500	1700	2000	2500	2500	2500	2500	2500	2500	2500	3000	3000
			MC	2500	3000	3500	3500	3500	3500	4500	4500	4500	4500	4500	4500	4500	4500
Medial no-load running torque ($n_1=3000$ rpm) (At 20 °C gearhead temperature)	T_{012}	Nm	MF	18.0	14.0	12.0	9.0	7.0	6.0	4.5	4.5	4.0	4.0	4.0	4.0	3.5	3.5
			MC														
Maximum input speed	n_{1Max}	min ⁻¹	MF	2500	2500	2500	2500	2500	3500	3500	3500	3500	3500	3500	3500	3500	3500
			MC	3400	6000	6000	6000	6000	6000	6000	6000	6000	6000	6000	6000	6000	6000
Torsional backlash	j_t	arcmin	MF	Standard ≤ 3 / Reduced ≤ 1					Standard ≤ 5 / Reduced ≤ 3								
			MC	Standard ≤ 4 / Reduced ≤ 2					Standard ≤ 5 / Reduced ≤ 4								
Torsional rigidity	C_{t21}	Nm/arcmin		400					400								
Max. axial force **	F_{2AMax}	N		30 000					30 000								
Max. radial force **	F_{2RMax}	N		21 000					21 000								
Max. tilting moment	M_{2KMax}	Nm		3100					3100								
Efficiency at full load	η	%	MF	≥ 97					≥ 94								
			MC	≥ 98.5					≥ 96.5								
Service life (For calculation, see alpha Technical Basics catalog)	L_h	h	MF	> 20 000					> 20 000								
			MC	> 30 000					> 20 000								
Weight incl. adapter plate	m	kg		56.0					55.0								
Noise level ($n_1=2000$ rpm) ***	L_{PA}	dB(A)		≤ 70													
Max. permissible housing temperature		°C		+90													
Ambient temperature		°C		0 to +40													
Lubrication				Lubricated for lifetime													
Paint				Blue RAL 5002													
Direction of rotation				Motor and gearhead same direction													
Type of protection				IP 65													
Mass moment of inertia (Referring to the drive)	J_1	kgcm ²	48	-	-	-	-	-	34.5	31.5	30.8	30.0	29.7	28.5	28.3	28.1	28.0
			55	139.0	94.3	76.9	61.5	53.1	-	-	-	-	-	-	-	-	-
Clamping hub diameter (mm)																	

* For higher ambient temperature, reduce nominal input speed n_{1N} .
 ** In reference to the center of the output shaft.
 *** Measured at ratio $i = 5$ (without load).

Alternative output shaft versions

Keywayed output shaft in mm

E = Key to DIN 6885, page 1, Form A

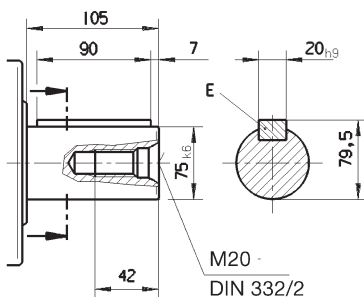

Involute gearing DIN 5480 in mm

X = W 70 x 2 x 30 x 34 x 6m, DIN 5480

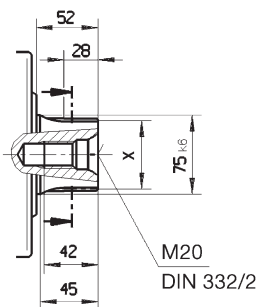

Conversion table

1 mm	= 0.039 in
1 Nm	= 8.85 in.lb
1 kgcm ²	= 8.85 x 10 ⁻⁴ in.lb.s ²
1 N	= 0.225 lb _f
1 kg	= 2.21 lb _m

View A

Motor shaft diameter (mm)

View B

1-stage

B →

MF/MC bis 60^④

← A

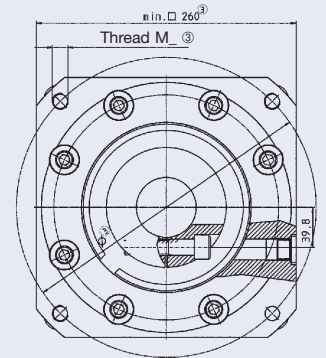
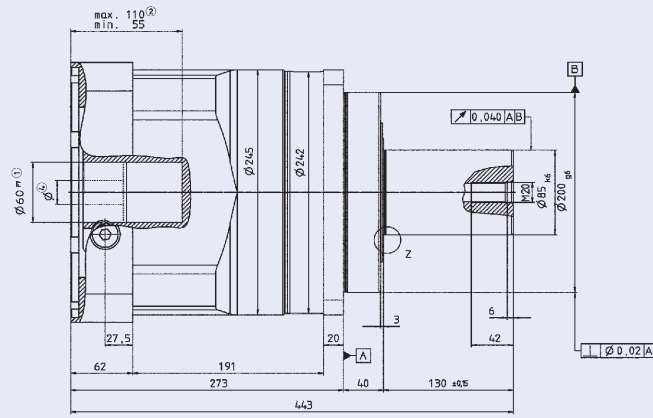
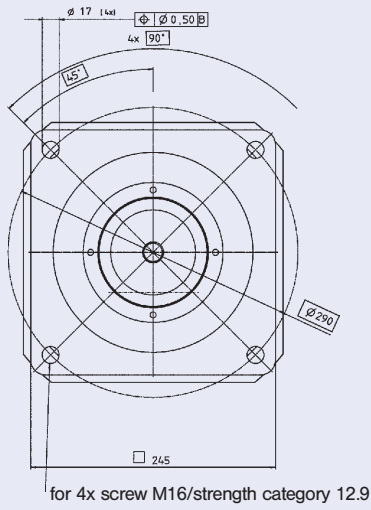

2-stage

B →

MF/MC bis 48^④

← A

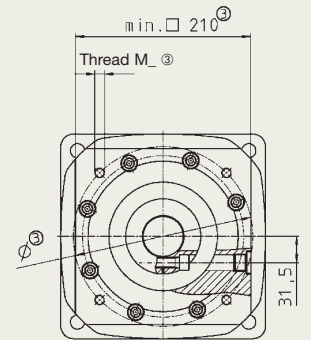
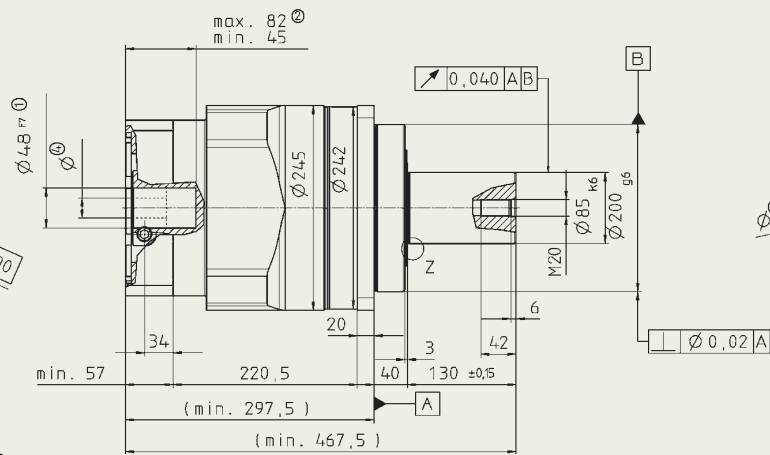
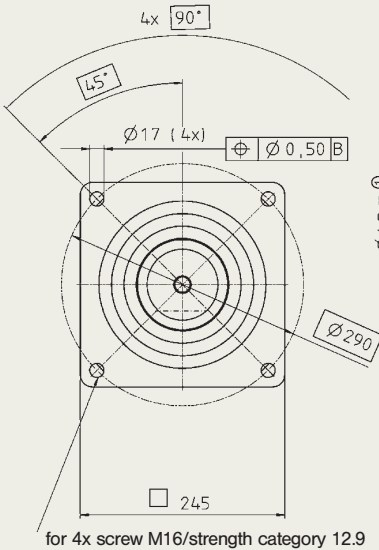

Z: Detail

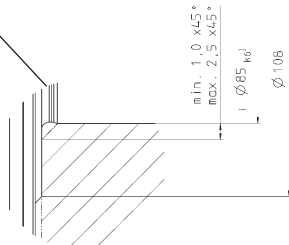

Dimensions without specified tolerances ±1 mm.

- ① Check motor shaft fit.
- ② Min./max. permissible motor shaft length. Longer motor shaft is possible. Please call alpha.
- ③ The dimensions depend on the motor.
- ④ Smaller motor shaft diameter is compensated by a bushing with at least 1 mm thickness (see page 34).

⚠ Motor mounting according to operating manual.

Technical Specifications SP+ 240

			1-stage					2-stage									
Ratio	i		3	4	5	7	10	16	20	25	28	35	40	50	70	100	
Maximum acceleration torque (Max. 1000 cycles per hour)	T_{2B}	Nm	MF	2750	4500	4500	4300	3400	4500	4500	4500	4500	4500	4000	4300	4300	3400
			MC	870	1300	1370	1430	1500	1300	1370	1370	1430	1370	1300	1370	1430	1500
Nominal output torque	T_{2N}	Nm	MF	1500	2500	2500	2300	1300	2500	2500	2500	2500	2500	2500	2300	1300	
			MC	560	860	900	940	1000	860	900	900	940	900	860	900	940	1000
Emergency stop torque (Permissible 1000 times during the lifespan of the gearhead)	T_{2Not}	Nm		6800	8500	8500	8500	6800	8500	8500	8500	8500	8500	8500	8500	6800	
Nominal input speed (At 20 °C ambient temperature) *	n_{1N}	min ⁻¹	MF	1000	1000	1200	1500	1700	2300	2500	2500	2500	2500	2500	2500	2800	2800
			MC	2000	2500	3000	3000	3000	3500	4500	4500	4500	4500	4500	4500	4500	4500
Medial no-load running torque ($n_1=3000$ rpm) (At 20 °C gearhead temperature)	T_{012}	Nm	MF	22.0	17.0	14.0	12.0	8.0	7.5	6.5	5.5	5.0	4.5	4.5	4.5	4.0	4.0
			MC														
Maximum input speed	n_{1Max}	min ⁻¹	MF	2200	2200	2200	2200	2200	3500	3500	3500	3500	3500	3500	3500	3500	3500
			MC	3400	4000	5000	5000	5000	6000	6000	6000	6000	6000	6000	6000	6000	6000
Torsional backlash	j_t	arcmin	MF	Standard ≤ 3 / Reduced ≤ 1					Standard ≤ 5 / Reduced ≤ 3								
			MC	Standard ≤ 4 / Reduced ≤ 2					Standard ≤ 5 / Reduced ≤ 4								
Torsional rigidity	C_{t21}	Nm/arcmin	550					550									
Max. axial force **	F_{2AMax}	N	33 000					33 000									
Max. radial force **	F_{2RMax}	N	30 000					30 000									
Max. tilting moment	M_{2KMax}	Nm	5000					5000									
Efficiency at full load	η	%	MF	≥ 97					≥ 94								
			MC	≥ 98.5					≥ 96.5								
Service life (For calculation, see alpha Technical Basics catalog)	L_h	h	MF	$> 20\ 000$					$> 20\ 000$								
			MC	$> 30\ 000$					$> 30\ 000$								
Weight incl. adapter plate	m	kg	83.0					80.6									
Noise level ($n_1=2000$ rpm) ***	L_{PA}	dB(A)	≤ 70														
Max. permissible housing temperature		°C	$+90$														
Ambient temperature		°C	0 to $+40$														
Lubrication	Lubricated for lifetime																
Paint	Blue RAL 5002																
Direction of rotation	Motor and gearhead same direction																
Type of protection	IP 65																
Mass moment of inertia (Referring to the drive)	J_1	kgcm ²	48	-	-	-	-	-	39.2	34.6	33.2	30.5	29.7	28.2	27.9	27.6	27.5
			60	260.2	198.2	163.0	84.4	70.8	-	-	-	-	-	-	-	-	-
Clamping hub diameter (mm)																	

- * For higher ambient temperature, reduce nominal input speed n_{1N} .
 ** In reference to the center of the output shaft.
 *** Measured at ratio $i = 5$ (without load).

Alternative output shaft versions

Keywayed output shaft in mm

E = Key to DIN 6885, page 1, Form A

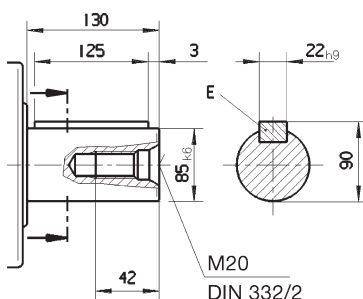

Involute gearing DIN 5480 in mm

X = W 80 x 2 x 30 x 38 x 6m, DIN 5480

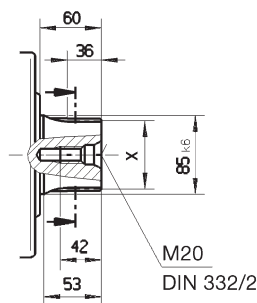

Conversion table

1 mm	= 0.039 in
1 Nm	= 8.85 in.lb
1 kgcm ²	= 8.85×10^{-4} in.lb.s ²
1 N	= 0.225 lb _f
1 kg	= 2.21 lb _m

SP⁺ Innovation

Easy error-free motor mounting

Mounting in a single step by tightening one clamping screw.

Ordering is independent of mounting position

New design eliminates need to specify mounting position on order, reducing error possibilities.

Standard IP65 protection class

Protection from low-pressure water-jets.

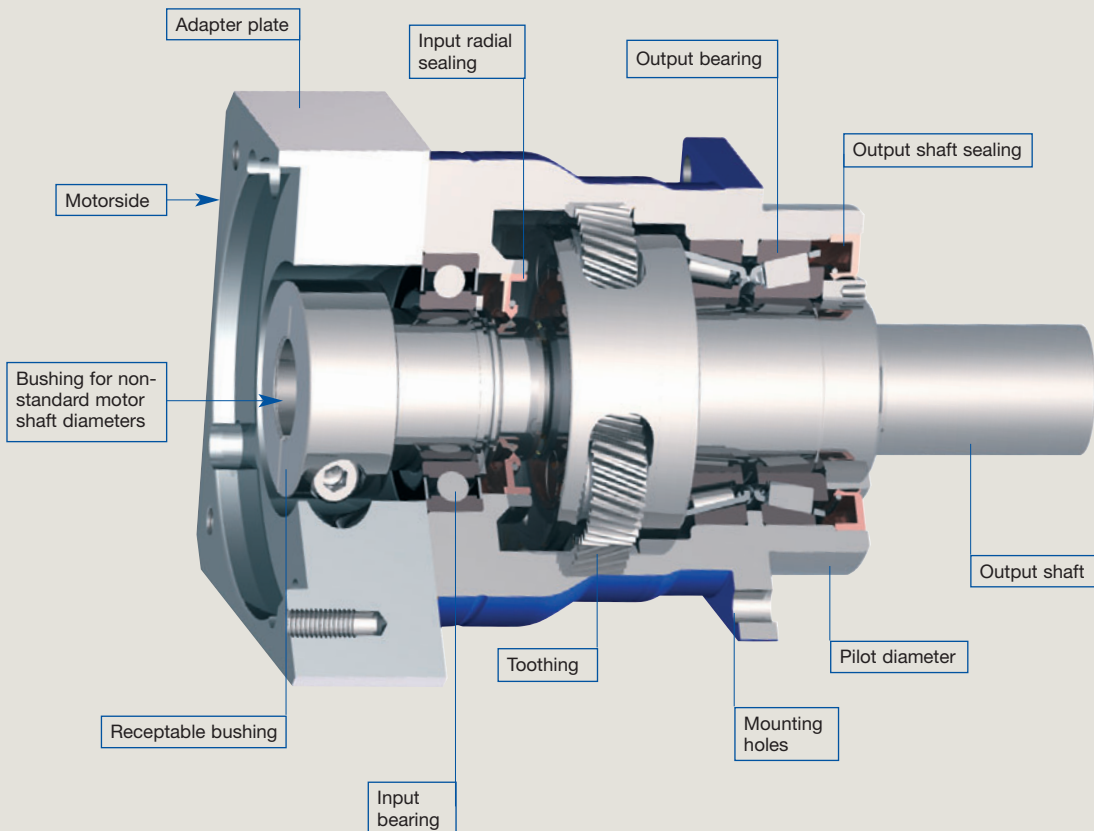

Symbols and Index

Symbol	Unit	Designation
C	Nm (in.lb)/arcmin	Rigidity
F	N (lb _f)	Force
i	-	Ratio
j	arcmin	Backlash
J	kgcm ² (in.lb.s ²)	Mass moment of inertia
L	h	Service life
M	Nm (in.lb)	Moment
n	rpm	Speed
η	%	Efficiency
T	Nm (in.lb)	Torque

Index	
capital letters	Permissible values
small letters	Actual values
1	Input
2	Output
A/a	Axial
B/b	Acceleration
h	Hours
K/k	Tilt
m	Mean
Max/max	Maximum
Mot	Motor
N	Nominal
Not/not	Emergency stop
0	No-load running
R/r	Radial
t	Torsional

Quick Selection

The following chart can be used to quickly select a gearhead. However, for best results, we recommend that you utilise the gearhead selection charts in the **alpha Technical Basics** catalog (can be downloaded from www.alphagetriebe.com) or use alpha's **Cymex® 3.0** servo/gearhead sizing software to design your drive train.

<p>Cyclic operation S5 Number of cycles ≤ 1000/hour</p> <p>Duty cycle < 60 % and < 20 min.*</p>	<ol style="list-style-type: none"> Using servomotor characteristic data, determine the maximum motor acceleration torque: $T_{MaxMot} \text{ [Nm (in.lb)]}$ Determine maximum acceleration torque at the gearhead output: T_{2b} [Nm] $T_{2b} = T_{MaxMot} \cdot i \text{ (ratio)}$ Compare the maximum acceleration torque just calculated with the permissible acceleration torque (T_{2B}) for the selected gearhead from pages 9-27. Requirement: $T_{2b} \leq T_{2B}$ If not, choose another gearhead. 	<ol style="list-style-type: none"> Verify that the clamping hub diameter (table on page 34) is OK for the selected servomotor. Compare the motor shaft length, L_{Mot} (mm), with the min. and max. clamping hub depth in the dimensional sketches.
<p>Continuous operation S1</p> <p>Duty cycle ≥ 60 % or ≥ 20 min.*</p>	<ol style="list-style-type: none"> Calculate after checking for cyclical operation S5. Determine the motor nominal torque: $T_{1NMot} \text{ [Nm (in.lb)]}$ Determine the rated load torque at the gearhead output: T_{2n} [Nm] $T_{2n} = T_{1NMot} \cdot i \text{ (ratio)}$ 	<ol style="list-style-type: none"> Compare the calculated rated load torque with the permissible rated torque (T_{2n}) for the selected gearhead from pages 9-27. Requirements: $T_{2n} \leq T_{2N}$ If not, choose another gearhead. Determine the nominal input speed n_{1n} in rpm and compare with permissible nominal input speed of the gearhead, n_{1N}. Requirements: $n_{1n} \leq n_{1N}$ Verify proper clamping hub diameter and motor shaft length as in steps 4 & 5 above (S5).

* General guidelines for most applications. Contact alpha if assistance is needed for special cases.

Ordering Key

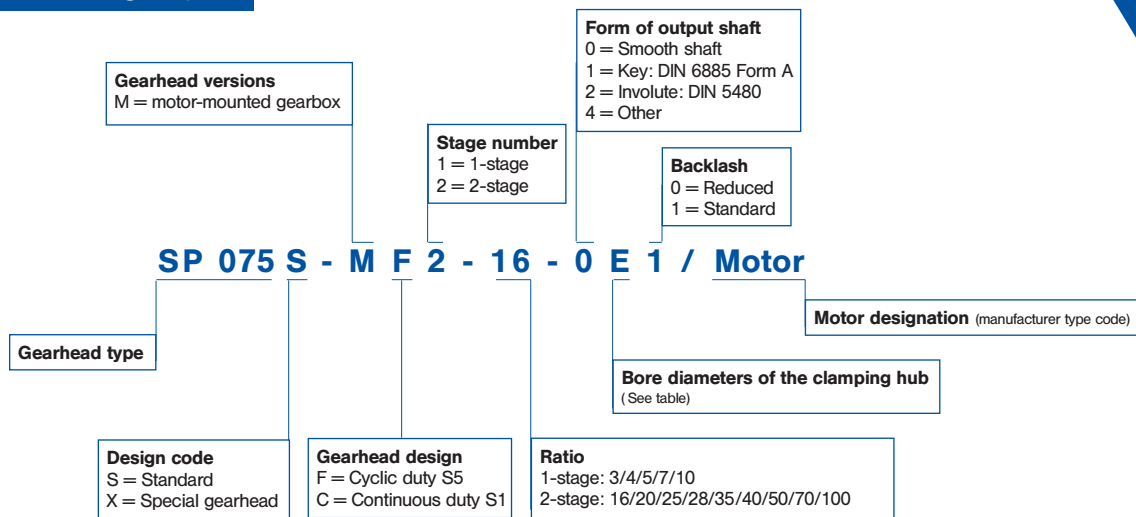

Table of clamping hub diameters for MF version;
 MC version use only diameter in bold

Gearhead stages	1 / 2	1 / 2	1 / 2	1 / 2	1 / 2	1 / 2	1 / 2
Motor shaft diameter (mm)*	060	075	100	140	180	210	240
11	B / B	- / B	- / -	-	-	-	-
14	C / C	C / C	- / C	-	-	-	-
19	E / +	E / E	E / E	- / E	-	-	-
24	+	G / +	G / G	G / G	- / G	-	-
28	+	+	H / +	- / -	- / -	-	-
32	+	+	- / +	I / -	- / I	- / -	- / -
38	+	+	K / +	K / K	K / K	- / -	- / -
48	+	+	+	M / +	M / M	- / M	- / M
55	+	+	+	+	+	N / +	- / +
60	+	+	+	+	+	+	O / +

- Select next larger character
 + Select next larger gearhead

* If your motor shaft diameter is not listed, add 2 mm to diameter and select next higher size.

Bushing

If the diameters of the motor shaft and the clamping hub do not match, a bushing is used.
 Minimum wall thickness of the bushing is 1 mm.

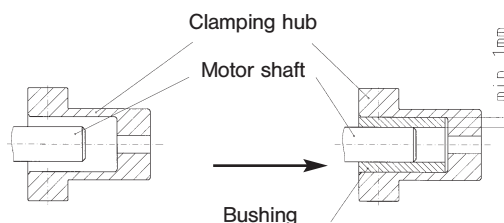

alpha's **Cymex**[®] calculation software makes it easier than ever to design the most complex drive trains with just a few mouse clicks.

application – gearhead – motor

Cymex[®] simplifies technical documentation, and customised engineering designs are possible at any time thanks to data in CAD format.

Use **Cymex**[®].

easy – quick – reliable

Direct access: www.cymex.de

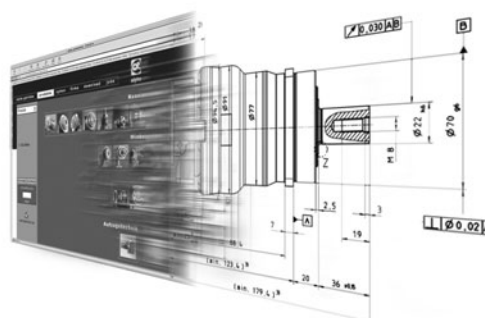

Additional **alpha** products



LP+ & LPB+ – Value Line Economic and multi-talented

Low-backlash gear reducers with output shaft for economical servo applications.
Torsional backlash ≤ 8 arcmin.
Acceleration torque up to 450 Nm.
Optional available as LPB+, with geared pulley mount.

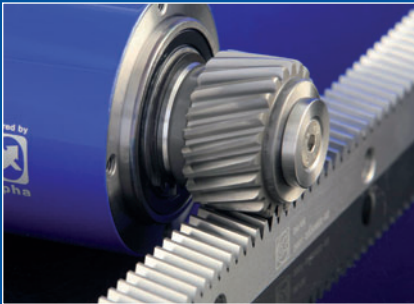

Rack & Pinion System

PRECISION SYSTEM – For exacting dynamics and precision requirements in high-end applications
SMART SYSTEM – For flexible mounting with more degrees of freedom in mid-range applications
ECONOMY SYSTEM – For standard linear tasks in economy applications



TP+ & TP+ HIGH TORQUE® – Compact Precision

Low-backlash planetary gear reducers with output flange. Qualified for highest positioning accuracy and high-dynamic cycle operation.
High torsional and tilting rigidity.
Torsional backlash < 1 arcmin.
Acceleration torque up to 10.000 Nm.



Hypoid Gearhead

Right-angle gearhead of highest precision and compactness. Torsional backlash ≤ 4 arcmin.
Acceleration torque up to 640 Nm.
Output shaft variations:
SK+: smooth, keywayed, involute toothing to DIN 5480
TK+: flange
HG+: hollow shaft



alphira® – the basic precision

low backlash / low friction / alpha quality
For stepper and basic server applications.
Acceleration torque up to 200 Nm.



Hypoid Planetary Gearhead

Right-angle planetary gearhead of highest precision and power density.
Torsional backlash ≤ 2 arcmin.
Acceleration torque up to 1600 Nm.
Output shaft variations:
SPK+: smooth, keywayed, involute toothing to DIN 5480
TPK+: flange

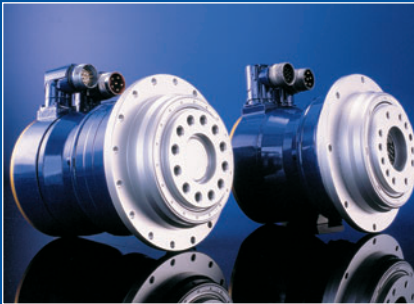

TPM & TPMA - Servoactuators

Ultra-compact and highly precise brushless gear motors featuring high dynamics, high torsional stiffness and a torsional backlash of just ≤ 1 arcmin.
Acceleration torque up to 2600 Nm.
Up to 60 % shorter overall length and much lower weight than conventional servomotor-gearhead designs.



Coupling – TL / BC / EC

Patented, backlash-free, compact and torsionally stiff metal bellows and safety couplings. Acceleration torque up to 10,000 Nm
Disengagement in 1 – 3 ms
Belt tension 100 – 12.000 N.
Self-adjusting

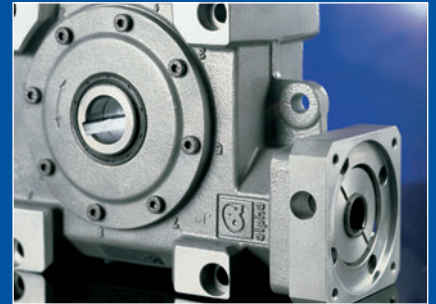

V - Drive®

Right-angle gearhead – short and compact.
Torsional backlash ≤ 3 arcmin.
Acceleration torque up to 1469 Nm.
Options output:
VDS: smooth, keywayed, involute toothing to DIN 5480
VDT: flange
VDH: hollow shaft, smooth or keywayed

For further information, order your personal brochure from:
Phone +49 7931 493-0

or download the digital version:
www.alphagetriebe.de

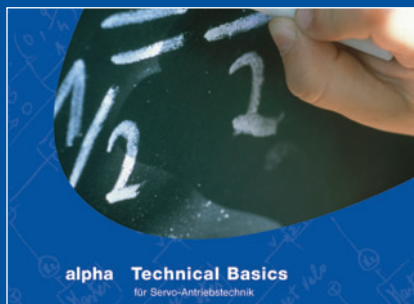

alpheno®
Rendez-vous with the future!

alpha international:



alpha getriebebau GmbH
Walter-Wittenstein-Str. 1
97999 Igersheim · Germany

Phone: +49 7931 493 -0
Telefax: +49 7931 493 -200
info@alphagetriebe.de
www.alphagetriebe.de



alpha

a **WITTENSTEIN AG** company